

DIN 30670

DIN

ICS 23.040.10; 23.040.40

Together with
DIN EN 10288:2003-12,
supersedes
DIN 30670:1991-04**Polyethylene coatings on steel pipes and fittings –
Requirements and testing,
English translation of DIN 30670:2012-04**Polyethylen-Umhüllungen von Rohren und Formstücken aus Stahl –
Anforderungen und Prüfungen,
Englische Übersetzung von DIN 30670:2012-04Gainage du polyéthylène pour des tubes et des pièces ajustées d'acier –
Exigences et essais,
Traduction anglaise de DIN 30670:2012-04

Document comprises 37 pages

Translation by DIN-Sprachendienst.

In case of doubt, the German-language original shall be considered authoritative.

Contents

	Page
Foreword.....	5
1 Scope	7
2 Normative references	7
3 Terms and definitions	8
4 Symbols and abbreviations	9
5 Coating.....	9
5.1 General.....	9
5.2 Types of coating	9
6 Information to be supplied by the purchaser	10
6.1 Mandatory information.....	10
6.2 Order options	10
7 Application of the coating.....	10
7.1 General.....	10
7.2 Surface preparation	10
7.3 Composition of the coating	10
7.3.1 General.....	10
7.3.2 Epoxy resin primer	12
7.3.3 PE adhesive.....	12
7.3.4 Polyethylene coating	12
7.3.5 Cutback.....	13
8 Requirements	13
8.1 General.....	13
8.2 Material properties.....	13
8.3 Production monitoring	17
8.3.1 Surface preparation	17
8.3.2 Pipe coating.....	17
9 Inspection and testing.....	18
9.1 General.....	18
9.2 Inspection documents.....	18
9.3 Types and frequency of tests	18
10 Repairs	21
11 Marking	21
12 Handling, transportation and storage.....	21
Annex A (normative) Inspection of thickness.....	22
Annex B (normative) Degree of cure of the epoxy resin layer	23
B.1 General.....	23
B.2 Apparatus	23
B.3 Description of procedure	23
B.3.1 Sampling.....	23
B.3.2 Measurement.....	23
B.3.3 Evaluation.....	23
Annex C (normative) Cathodic disbondment (CD test).....	24
C.1 General.....	24
C.2 Apparatus	24
C.3 Procedure	26
C.3.1 Sampling.....	26

	Page
C.3.2 Measurement	26
C.3.3 Evaluation	26
Annex D (normative) Peel strength	27
D.1 General	27
D.2 Apparatus	27
D.3 Procedure	29
D.3.1 Sample preparation	29
D.3.2 Measurement	29
D.3.3 Evaluation	29
Annex E (normative) Continuity (holiday detection)	30
E.1 General	30
E.2 Apparatus	30
E.3 Procedure	30
Annex F (normative) Elongation at break	31
F.1 General	31
F.2 Apparatus	31
F.3 Procedure	31
F.3.1 Sample preparation	31
F.3.2 Measurement	31
F.3.3 Evaluation	31
Annex G (normative) Measuring the melt mass-flow rate (MFR)	32
G.1 General	32
G.2 Apparatus	32
G.3 Procedure	32
G.3.1 Sampling	32
G.3.2 Measurement	32
G.3.3 Evaluation	32
Annex H (normative) Impact resistance and low temperature impact resistance	33
H.1 General	33
H.2 Apparatus	33
H.3 Procedure	33
H.3.1 Test specimen preparation	33
H.3.2 Procedure and evaluation	33
Annex I (normative) Indentation resistance	34
I.1 General	34
I.2 Apparatus	34
I.3 Procedure	34
I.3.1 Test piece preparation	34
I.3.2 Procedure and evaluation	34
Annex J (normative) Specific electrical coating resistance	35
J.1 General	35
J.2 Apparatus	35
J.3 Procedure	35
J.3.1 Test piece preparation	35
J.3.2 Procedure and evaluation	35
Annex K (normative) UV resistance	36
K.1 General	36
K.2 Apparatus	36
K.3 Procedure	36
K.3.1 Sample preparation	36
K.3.2 Measurement	36
K.3.3 Evaluation	36

	Page
Annex L (normative) Thermal ageing resistance	37
L.1 General	37
L.2 Apparatus	37
L.3 Procedure	37
L.3.1 Sample preparation	37
L.3.2 Measurement	37
L.3.3 Evaluation	37

Foreword

This standard has been revised by Working Committee NA 032-02-09 AA *Außenkorrosion* of the *Normenausschuss Gastechnik* (NAGas) (Gas Technology Standards Committee). The previous edition of DIN 30670 was published in 1991 and could not be revised for a long time because work was being carried out on the European standards project EN 10288. The present edition of DIN 30670 not only covers fields of application that are not dealt with in DIN EN ISO 21809-1 and DIN EN 10288, it also takes into consideration the current state of the art, not only as regards the tests and test frequencies specified here for the first time, but also as regards various product requirements.

The option of agreeing on design temperatures for different types of coating, and of agreeing on a special, greater coating thickness have been maintained here. A 1 mm thickness is necessary for the polyethylene coating layer in terms of corrosion protection, while the remaining layer thicknesses serve to improve resistance to mechanical loading.

A check of the effectiveness of stabilizing agents by controlling the MRF before and after extrusion has now been specified. The test of the degree of cure of the epoxy resin coating by means of DSC measurement is also new, as is the cathodic disbondment test, which is frequently required at international level.

Extensive investigations and practical experience have shown that, regardless of the manufacturing method, disbondment of damaged polyethylene coatings can occur depending on the salinity of the soil water and the extent of cathodic polarization. However this involves neither an increased risk of corrosion (underrusting) nor an increase in the protective current density requirement in cathodic corrosion protection. The cathodic disbondment test thus does not serve to evaluate the boundary phase reaction in the case of damaged coatings, which is unavoidable in practice, but is primarily a means of assessing the boundary areas between the epoxy resin layer and the steel substrate. This test has therefore been specified here to evaluate surface preparation. For single-layer sintered polyethylene coatings, it is difficult to achieve the required peel strength without suitable surface preparation, and so the cathodic disbondment test is not required for single-layer sintered polyethylene coatings.

The peel strength requirements have been adapted to the production methods commonly used today. The differences between sintered and extruded (by sleeve extrusion or sheet extrusion) coatings have been taken into consideration. Experience gained in the transport and laying of pipes and pipelines with polyethylene coatings has shown that a high bond strength is necessary to reduce possible mechanical damage to the pipes. Bond strength is not a significant factor with regard to the protection the coating provides against corrosion, as long as the thickness and quality of the coating meet the requirements of this standard and as long as the coating is undamaged and is in good contact along the entire pipe length.

In the Explanatory Notes to DIN 30670:1991-04 reference was made to the possibility of testing stress crack formation under the influence of wetting agents. Today, findings confirm that the testing of new materials exposed to wetting agents at high temperatures does not have any significance as regards ageing-related stress cracking behaviour. Relevant changes to the materials during operation, such as a reduction of elongation-at-break and tear strength values – and thus changes to the fracture properties of the polyethylene – are not well-described in short-term tests involving exposure to wetting agents even at higher test temperatures. The saponification of adhesive components, and thus stress crack formation due to the effects of wetting agents, are not possible when an epoxy resin primer and adhesive copolymers are used in a three-layer coating system. This also applies for single-layer sintered polyethylene coatings. For this reason, a wetting agent test is not specified in this standard.

Attention is drawn to the possibility that some of the elements of this document may be the subject of patent rights. DIN [and/or the DKE] shall not be held responsible for identifying any or all such patent rights.

Amendments

The standard differs from DIN 30670:1991-04 as follows:

- a) the scope has been restricted;
- b) requirements and testing of the epoxy resin primer of three-layer polyethylene coatings are specified;
- c) test frequencies are now specified;
- d) current standards have been taken into consideration;
- e) requirements for documentation are specified;
- f) separate requirements for the different coating methods (sintering or extrusion) are specified;
- g) the temperature has been modified;
- h) testing of cathodic disbondment is specified;
- i) two-layer extruded polyethylene coatings are no longer included as they are covered by DIN EN 10288;
- j) agreement on special coating thicknesses is now permitted.

Previous editions

DIN 30670: 1974-02, 1980-07, 1991-04

1 Scope

This standard specifies requirements for factory-applied three-layer extruded polyethylene-based coatings, and one- or multi-layered sintered polyethylene-based coatings for the corrosion protection of steel pipes and fittings.

The coatings are suitable for the protection of buried or submerged steel pipes at design temperatures of -40 °C up to $+80\text{ °C}$.

The present standard specifies requirements for coatings that are applied to longitudinally or spirally welded or seamless steel pipes and fittings used for the construction of pipelines for conveying liquids or gases.

Applying this standard ensures that the PE coating provides sufficient protection against the mechanical, thermal and chemical loads occurring during operation, transport, storage and installation.

DIN EN ISO 21809-1 specifies requirements at international level for three-layer extruded polyethylene- and polypropylene-based coatings for steel pipes for petroleum and natural gas pipeline transportation systems. The following fields of application are not covered by DIN EN ISO 21809-1:

- all polyethylene-based coatings for steel pipes and fittings used for the conveyance and distribution of water and wastewater,
- all polyethylene-based coatings for steel pipes and fittings in distribution pipelines for gaseous and liquid media,
- single- and multi-layer sintered polyethylene-based coatings for steel pipes and fittings used for transport pipelines and distribution pipelines

The present standard remains valid for the above fields of application. Two-layer polyethylene-based coatings are standardized at European level in DIN EN 10288 which was published in December 2003.

2 Normative references

The following referenced documents are indispensable for the application of this document. For dated references, only the edition cited applies. For undated references, the latest edition of the referenced document (including any amendments) applies.

DIN EN 10204:2005-01, *Metallic products — Types of inspection documents*

DIN EN 10288, *Steel tubes and fittings for onshore and offshore pipelines — External two layer extruded polyethylene based coatings*

DIN EN ISO 306, *Plastics — Thermoplastic materials — Determination of Vicat softening temperature (VST)*

DIN EN ISO 527-1, *Plastics — Determination of tensile properties — Part 1: General principles*

DIN EN ISO 527-2, *Plastics — Determination of tensile properties — Part 2: Test conditions for moulding and extrusion plastics*

DIN EN ISO 527-3, *Plastics — Determination of tensile properties — Part 3: Test conditions for films and sheets*

DIN EN ISO 868, *Plastics and ebonite — Determination of indentation hardness by means of a durometer (Shore hardness)*

DIN EN ISO 1133-1, *Plastics — Determination of the melt mass-flow rate (MFR) and melt volume-flow rate (MVR) of thermoplastics — Part 1: Standard method*

DIN EN ISO 1183-1, *Plastics — Methods for determining the density of non-cellular plastics — Part 1: Immersion method, liquid pycnometer method and titration method*

DIN EN ISO 2808, *Paints and varnishes — Determination of film thickness*

DIN EN ISO 4287, *Geometrical Product Specifications (GPS) — Surface texture: Profile method — Terms, definitions and surface texture parameters*

DIN EN ISO 4892-2, *Plastics — Methods of exposure to laboratory light sources — Part 2: Xenon-arc lamps*

DIN EN ISO 8130-1, *Coating powders — Part 1: Determination of particle size distribution by sieving*

DIN EN ISO 8130-2, *Coating powders — Part 2: Determination of density by gas comparison pycnometer (referee method)*

DIN EN ISO 8130-3, *Coating powders — Part 3: Determination of density by liquid displacement pycnometer*

DIN EN ISO 8130-6, *Coating powders — Part 6: Determination of gel time of thermosetting coating powders at a given temperature*

DIN EN ISO 8501-1, *Preparation of steel substrates before application of paints and related products — Visual assessment of surface cleanliness — Part 1: Rust grades and preparation grades of uncoated steel substrates and of steel substrates after overall removal of previous coatings*

DIN EN ISO 9001, *Quality management systems — Requirements*

DIN EN ISO 11357-1, *Plastics — Differential scanning calorimetry (DSC) — Part 1: General principles*

DIN EN ISO 11357-2, *Plastics — Differential scanning calorimetry (DSC) — Part 2: Determination of glass transition temperature*

DIN EN ISO 11357-6, *Plastics — Differential scanning calorimetry (DSC) — Part 6: Determination of oxidation induction time (isothermal OIT) and oxidation induction temperature (dynamic OIT)*

DIN EN ISO 15512, *Plastics — Determination of water content*

DIN EN ISO 21809-1:2011-10, *Petroleum and natural gas industries — External coatings for buried or submerged pipelines used in pipeline transportation systems — Part 1: Polyolefin coatings (3-layer PE and 3-layer PP)*

3 Terms and definitions

For the purposes of this document, the terms and definitions in DIN EN ISO 21809-1 and the following apply.

3.1

product manufacturer

supplier of the coating material suitable for application to the product to be coated

NOTE See also DIN EN 10288.

3.2

coater

person responsible for applying the coating material to the steel components to be coated in accordance with the requirements of this standard or the deviations therefrom as agreed in the tender specification and in the order

NOTE See also DIN EN 10288.

3.3

purchaser

company which buys the coated products

NOTE See also DIN EN 10288.

4 Symbols and abbreviations

A_0	elongation at break in %
W	impact energy in J
I	current in A
L_0, L_1	lengths used to determine elongation (given in same unit, e.g. m or mm)
MFR	melt mass-flow rate in g/(10 min)
OIT	oxidation induction time as in DIN EN ISO 11357-6
R_z	roughness parameter (average roughness from five successive evaluation areas measured according to DIN EN ISO 4287)
r_u	specific electrical coating resistance in Ω/m^2
S	area in m^2
U	voltage in V
ΔT	difference in the dew point temperature in $^{\circ}C$
ΔT_{g2}	difference in the glass transition temperature in $^{\circ}C$
φ	correction factor for the impact resistance test
DSC	differential scanning calorimetry as in DIN EN ISO 11357-1

5 Coating

5.1 General

Extruded coatings comprise three layers: an epoxy resin primer, a PE adhesive and an extruded polyethylene outer layer. The epoxy resin primer is applied as a powder. The adhesive can be applied either as a powder or by extrusion. For extruded coatings a differentiation is made between sleeve extrusion and sheet extrusion. Sintered polyethylene coatings are single- or multi-layer systems. The polyethylene powder is fused onto the pre-heated component until the desired coating thickness is reached.

5.2 Types of coating

There are two areas of application based on the design temperature. The coating type is to be stated in the purchase order. Other design temperatures may be agreed between the purchaser and the coater.

Table 1 — Types of coating

Type	Area of application	
	N	S
Design temperatures for sintered polyethylene coatings	from $-20\text{ }^{\circ}C$ up to $+50\text{ }^{\circ}C$	from $-40\text{ }^{\circ}C$ up to $+70\text{ }^{\circ}C$
Design temperatures for extruded polyethylene coatings	from $-20\text{ }^{\circ}C$ up to $+60\text{ }^{\circ}C$	from $-40\text{ }^{\circ}C$ up to $+80\text{ }^{\circ}C$

6 Information to be supplied by the purchaser

6.1 Mandatory information

The following information shall be stated by the purchaser:

- number and dimensions of pipes or fittings to be coated;
- reference to this standard;
- type of coating.

6.2 Order options

The following optional information can be included in the order:

- design temperature (area of application “N” applies, unless otherwise stated);
- coating thickness class (coating thickness class “n” (see 7.3.4) applies, unless otherwise stated);
- inspection document, e.g. test report “type 2.2” as in DIN EN 10204 or other types of inspection document as in DIN EN 10204;
- a deviating cutback configuration;
- a deviating marking of coating;
- requirements for coating properties;
- deviations from the test frequencies;
- material requirements;
- coating colour.

7 Application of the coating

7.1 General

Materials shall be selected at the discretion of the coater because, depending on the installation and coating procedure, various materials can be used to comply with the minimum requirements specified in this standard for the finished coating. Any deviating requirements of the purchaser regarding the materials to be used shall be subject to agreement.

7.2 Surface preparation

The surface shall be prepared by removing rust by means of blast cleaning. Blast cleaning and any necessary subsequent work shall not result in the reduction of the minimum wall thickness specified in the technical delivery standards for the steel pipe. Residual abrasive dust shall be removed prior to coating.

7.3 Composition of the coating

7.3.1 General

While for three-layer extruded polyethylene coatings a differentiation is made between the epoxy resin primer, the adhesive and the PE coating materials, for sintered coatings – including three-layer sintered coatings – requirements only need to be taken into consideration for the polyethylene layer. Table 2 gives an overview of the necessary information to be included in the delivery documents and technical data sheets. This data relates to the raw materials and can differ from the values for the applied coating.

Table 2 — Required information to be included in the technical data sheets and delivery documents of the product manufacturer

Material	Property	Testing as in	Test certificate: conformity assessment (K) and/or batch testing (C)	Technical data sheets
General information	Material designation	–	K, C	yes
	Product manufacturer	–	K, C	yes
	Storage conditions	–	–	yes
	Batch number	–	K, C	–
Epoxy resin	Particle size distribution	DIN EN ISO 8130-1	C	yes
	Production date	–	C	–
	Shelf life	–	–	yes
	Density	DIN EN ISO 8130-2	C	yes
	DSC (ΔT_{g2})	DIN EN ISO 11357-1	C	yes
	Gel time	DIN EN ISO 8130-6	C	yes
	Water content	DIN EN ISO 15512	C	yes
Adhesive^a	Particle size distribution	–	K	–
	Production date	–	C	–
	MFR	DIN EN ISO 1133-1	C	yes
	Density	DIN EN ISO 1183-1	C	yes
	Vicat softening temperature	DIN EN ISO 306	K	yes

Table 2 (continued)

Material	Property	Testing as in	Test certificate: conformity assessment (K) and/or batch testing (C)	Technical data sheets
Polyethylene	OIT	DIN EN ISO 11357-1	K, C	yes
	Density	DIN EN ISO 1183-1	C	yes
	MFR (190 °C/2,16 kg)	DIN EN ISO 1133-1	C	yes
	Carbon black content ^b	–	C	yes
	Elongation at break ^c	DIN EN ISO 527-2	–	yes
	Stress at yield ^c	DIN EN ISO 527-2	–	yes
	Tear strength ^c	DIN EN ISO 527-2	–	yes
	Softening temperature	DIN EN ISO 306	–	yes
	Shore hardness ^c	DIN EN ISO 868	–	yes
<p>^a The information for adhesives refers to the unground material and cannot be tested by the coater in the case of materials applied as powders.</p> <p>^b For black-coloured materials.</p> <p>^c Information as to whether specimens were compression-moulded, sintered or extruded is also required..</p>				

7.3.2 Epoxy resin primer

The epoxy resin primer is to be applied in powder form. The minimum layer thickness is 60 µm. The thickness shall be monitored in accordance with DIN EN ISO 2808, Method 1A.

7.3.3 PE adhesive

The PE adhesive can be applied in powder form or extruded. The minimum layer thickness is 140 µm. The thickness shall be monitored in accordance with DIN EN ISO 2808, Method 1A. The peel strength requirements vary depending on whether the adhesive was applied as a powder or was extruded.

7.3.4 Polyethylene coating

The polyethylene coating is applied either by sintering or by sleeve or sheet extrusion. The coating is to be cooled after application to avoid unwanted deformation during transport. Depending on the nominal size, there are different minimum values for the normal total coating thickness (n). In the case of increased mechanical loads (during transport, storage, installation, and as regards specific mass, stricter requirements) the minimum layer thickness shall be increased by 0,7 mm (in which case the thickness is indicated by “v” for *verstärkt*). Minimum layer thicknesses are given in Table 3 below. Greater, special thicknesses may be agreed and are indicated by the letter “s”. The total coating thickness (coating system thickness) is to be determined in accordance with Annex A.

Table 3 — Guideline values for the total thickness of the polyethylene coating system

Nominal size	Minimum thickness ^a (mm)	
	normal (n)	increased (v)
≤ DN 100	1,8	2,5
> DN 100 ≤ DN 250	2,0	2,7
> DN 250 < DN 500	2,2	2,9
≥ DN 500 < DN 800	2,5	3,2
≥ DN 800	3,0	3,7

^a The thickness may be less than the minimum thickness locally as long as these local areas do not exceed 5 cm² per 1 m length of pipe and the difference between the actual thickness and the minimum thickness is not greater than 10 %.

Translator's note. The table in this translation is the corrected version which will be published in a Corrigendum to the German version of this standard.

7.3.5 Cutback

For pipes smaller than DN 600 the length of the cutback shall be no greater than 150 mm, for larger pipes the cutback shall be (150 ± 20) mm. For three-layer coatings, the epoxy resin and adhesive layers at the pipe ends shall be removed to at least 80 mm from the welding bevel. A not less than 20 mm strip of epoxy resin or epoxy resin and adhesive should extend from the cutback of the polyethylene coating. For coating thicknesses up to 2,2 mm the bevel angle shall be no greater than 45°, for greater coating thicknesses the bevel angle shall be no greater than 30°. Other end designs and/or angles may be agreed.

8 Requirements

8.1 General

The requirements for coatings in accordance with this standard apply to their condition at the time of delivery and help in assuring the quality of the materials used and the monitoring of the coating process.

8.2 Material properties

The required properties of the coating system and the materials used, as well as references to the relevant tests to be carried out, are summarized in Table 4 and Table 5. Other requirements may be agreed upon request and at the time of ordering.

Table 4 — Properties of sintered coatings

Property	Requirement	Testing as in	Notes
Degree of cure of epoxy resin	ΔT_g according to the manufacturer's specification	Annex B	
Cathodic disbondment (CD test)	23 °C/28 d or 60 °C/2 d max. 7 mm	Annex C	Applies only to three-layer coatings ^a
Peel strength^b	Single-layer method: Type N: 35 N/cm at 23 °C 15 N/cm at 50 °C Type S: 35 N/cm at 23 °C 15 N/cm at 70 °C Three-layer method: Type N: 45 N/cm (23 °C) 20 N/cm (50 °C) Type S: 70 N/cm (23 °C) 30 N/cm (70 °C)	Annex D	For system testing single values shall be no more than 25 % lower than the required average value.
Continuity (holiday detection)	No discharges	Annex E	25 kV test
Elongation at break (23 °C ± 2 °C)	min. 300 %	Annex F	
Impact resistance (23 °C ± 2 °C)	Type N: ≥ 5 J/mm Type S: ≥ 7 J/mm	Annex H	25 kV test No discharges
Low temperature impact resistance	Type N: ≥ 5 J/mm (-20 °C ± 2 °C) Type S: ≥ 7 J/mm (-40 °C ± 2 °C)	Annex H	25 kV test No discharges

Table 4 (continued)

Property	Requirement	Testing as in	Notes
Indentation resistance	Type N: max. 0,2 mm (23 °C) max. 0,3 mm (50 °C) Type S: max. 0,2 mm (23 °C) max. 0,4 mm (70 °C)	Annex I	
Specific electrical coating resistance (23 °C ± 2 °C)	$\geq 10^8 \Omega\text{m}^2$	Annex J	
UV resistance	$\Delta\text{MFR} \pm 35 \%$	Annex K	
Thermal ageing resistance	$\Delta\text{MFR} \pm 35 \%$	Annex L	
<p>^a For single-layer sintered coatings the CD text may be subject to agreement.</p> <p>^b For single-layer sintered coatings the level of adhesion of the polyethylene to the steel substrate shall be assessed.</p>			

Table 5 — Properties of extruded coatings

Property	Requirement	Testing as in	Notes
Degree of cure of epoxy resin	ΔT_g according to the manufacturer's specification	Annex B	
Cathodic disbondment (CD test)	23 °C/28 d or 60 °C/2 d max. 7 mm	Annex C	
Peel strength^b	<p>Sleeve extrusion</p> <p>Type N: 45 N/cm (23 °C) 15 N/cm (50 °C)</p> <p>Type S: 60 N/cm (23 °C) 25 N/cm (70 °C)</p> <p>Sheet extrusion</p> <p>Type N: 100 N/cm (23 °C) 20 N/cm (50 °C)</p> <p>Type S: 150 N/cm (23 °C) 30 N/cm (70 °C)</p>	Annex D	In case of break see D 3.3
Continuity (holiday detection)	No discharges	Annex E	25 kV test
Elongation at break (23 °C ± 2 °C)	min. 400 %	Annex F	
MFR On delivery of material /after application	$\Delta MFR \pm 20 \%$	Annex G	

Table 5 (continued)

Property	Requirement	Testing as in	Notes
Impact resistance (23 °C ± 2 °C)	Type N: ≥ 5 J/mm Type S: ≥ 7 J/mm	Annex H	25 kV test No discharges
Low temperature impact resistance	Type N: ≥ 5 J/mm (-20 °C ± 2 °C) Type S: ≥ 7 J/mm (-40 °C ± 2 °C)	Annex H	25 kV test No discharges
Indentation resistance	Type N: max. 0,2 mm (23 °C) max. 0,3 mm (50 °C) Type S: max. 0,2 mm (23 °C) max. 0,4 mm (70 °C)	Annex I	
Specific electrical coating resistance (23 °C ± 2 °C)	≥ 10 ⁸ Ωm ²	Annex J	
UV resistance	ΔMFR ± 35 %	Annex K	
Thermal ageing resistance	ΔMFR ± 35 %	Annex L	

8.3 Production monitoring

8.3.1 Surface preparation

The surfaces of steel pipes and fittings shall be blast-cleaned to grade SA2½ as in DIN EN ISO 8501-1. During surface preparation and the subsequent coating process the pipe surface temperature shall be at least 3 °C above the dew point. The surface roughness R_z shall be between 40 µm and 90 µm. After abrasive cleaning the quality of the pipe surface shall be visually checked. Prior to coating application, the metal surface of the steel pipe shall be free of all contaminants and deleterious matter such as dirt, oil, grease, weld beads, etc. which could be detrimental to the adhesion of the coating.

8.3.2 Pipe coating

Prior to coating, the pipe surface shall be warmed to the necessary temperature and this temperature is to be monitored. The same applies to the relevant extrusion line parameters. The appearance of the applied intermediate layers shall be regularly inspected. After it has cooled, the appearance and continuity of the coating system shall be visually assessed along the entire pipe length. The coating shall be of a uniform colour, have a smooth appearance and be free of holidays and other defects detrimental to the quality of the coating.

9 Inspection and testing

9.1 General

The inspection and testing of the coating and material properties is described in the Annexes to this standard. A differentiation is made between production control and system testing.

In system testing the required material properties and functional requirements on the coating components as in this standard are determined and documented. System testing is to be carried out every three years on each coating composition and for each coating method. System testing may be carried out by coaters themselves who comply with the requirements of DIN EN ISO 9001 or an equivalent management system.

Production control is assured by the coater. Production controls are to be carried out by the coater or a recognized materials testing body. If the material requirements specified in this standard are not met during a test carried out as part of production control, this test is to be repeated with twice the number of specimens. If the requirements are still not met, the production lot shall be blocked.

9.2 Inspection documents

An inspection document, generally a “type 2.2” test report as in DIN EN 10204:2005-01, 3.2, shall be issued as proof that the polyethylene coating meets requirements. Other documents may be agreed.

If the coater meets the requirements of DIN EN ISO 9001 or an equivalent management system, for the specific test a “type 3.1” inspection certificate as in DIN EN 10204:2005-01, 4.1, for example, can be issued as proof of compliance.

If the coater does not meet the requirements of DIN EN ISO 9001 or an equivalent management system, for the specific test a “type 3.2” inspection certificate as in DIN EN 10204:2005-01, 4.2, for example, can be issued as proof of compliance.

9.3 Types and frequency of tests

Table 6 contains information on the types and frequency of tests. Other test sequences can be agreed.

Table 6 — Type and frequency of tests

	Type of test	Frequency	Production control	System testing
Surface	Roughness	once per shift when modifications to the coating line are made	X	—
	ΔT (dew point)	once per shift when modifications to the coating line are made	X	—
Epoxy resin primer	Layer thickness	once per shift when modifications to the coating line are made	X	—
	Degree of cure	once per batch when modifications to the coating line are made	X	X 1 specimen
	CD test 23 °C/28 d	—	—	X 3 specimens
	CD test 60 °C/2 d	once per batch	X 1 specimen	X 3 specimens
PE adhesive	Layer thickness	once per shift when modifications to the coating line are made	X	—
	Peel strength 23 °C	once per shift when modifications to the coating line are made	X	X 3 specimens
	Peel strength Type N 50 °C	—	—	X 3 specimens
	Peel strength Type S 70 °C	—	—	X 3 specimens

Table 6 (continued)

	Type of test	Frequency	Production control	System testing
Polyethylene	Peel strength ^a 23 °C	once per PE batch when modifications to the coating line are made	X	X 3 specimens
	Peel strength ^a Type N 50 °C	—	—	X 3 specimens
	Peel strength ^a Type S 70 °C	—	—	X 3 specimens
	Layer thickness	three times per shift	X	—
	Continuity	100 %	X	—
	MFR On delivery of material /after application	once per batch when modifications to the coating line are made	X	—
	Elongation at break	once per batch ^b	X	X 5 specimens
	Impact resistance	once per batch ^b	X	X 1 specimen
	Low temperature impact resistance	—	—	X 1 specimen
	Indentation resistance	once per batch ^b	X	X 3 specimens
	Specific electrical coating resistance	—	—	X 1 specimen
	UV resistance	—	—	X 1 set of specimens

Table 6 — Type and frequency of tests (continued)

	Type of test	Frequency	Production control	System testing
Polyethylene	Thermal ageing resistance	—	—	X 1 set of specimens
^a For single-layer sintered coatings the level of adhesion of the polyethylene to the steel substrate shall be assessed. ^b For sintered coatings these coating properties are to be confirmed during system testing.				

10 Repairs

Steel pipes and fittings with localized defects (porosity, surface defects) as well as those which have been subjected to destructive control tests in accordance with this standard may be repaired.

For extruded coatings DIN EN ISO 21809-1 applies as appropriate. For sintered coatings the total defect area shall not exceed 10 cm² per m² coated area.

The coating materials that are used for repairing defects shall satisfy two conditions.

- They shall be suitable for protecting onshore and offshore pipelines under the required service conditions (e.g. design temperature).
- They shall be compatible with polyethylene coating which has been applied.

After application the repair shall be verified in accordance with Annex E. The repair shall be free from holidays.

Alternative provisions for repairs may be agreed.

11 Marking

Each pipe or pipeline component shall be marked with the following information:

- pipe manufacturer's code or name;
- coater's code and name (if different from the pipe manufacturer);
- reference to the pipe standard;
- reference to the coating standard giving the coating type as in Table 1 and the thickness class.

Marking shall be carried out using a suitable method such as stencil painting or printing, and shall be durable and legible.

12 Handling, transportation and storage

Coated steel pipes and fittings shall be handled without causing damage to the pipe ends or coating. The use of steel ropes, slings or any other equipment which could damage the coating or pipe ends is prohibited. During transportation, measures shall be taken to prevent damage to the steel pipes and fittings or to the coating. After delivery, pipes intended to be stored outdoors for a long period shall be protected from the effects of ultraviolet radiation.

Annex A (normative)

Inspection of thickness

The methods for inspecting thickness are described in DIN EN ISO 2808. The thickness of single layers and the total coating thickness shall be determined.

The thickness of the epoxy resin primer and PE adhesive layer shall be determined on at least three representative points on the surface distributed equally along the pipe circumference.

The total coating thickness shall be inspected using a non-destructive method according to DIN EN ISO 2808.

The thickness shall be measured using a magnetic, electromagnetic or ultrasonic thickness-measuring instrument having an accuracy of $\pm 10\%$. The instrument shall be suitable for and calibrated for the coating thickness range to be measured.

On each pipe being inspected carry out at least 12 measurements. For submerged arc welded pipes, an additional four thickness measurements shall be taken on the weld area. The measurements shall be made at points distributed along four equally spaced longitudinal lines at the intersection with three equally spaced circumferential lines and at a distance of at least 200 mm from the end of the coating.

Annex B (normative)

Degree of cure of the epoxy resin layer

B.1 General

Differential scanning calorimetry (DSC) shall be used to test the cured epoxy resin. The method is described in DIN EN ISO 11357-1 and ISO 11357-2. The method shall be carried out as in these standards unless there are deviating specifications in this Annex.

B.2 Apparatus

The test apparatus shall comprise the following components:

- a differential scanning calorimeter (DSC), with cooling accessory
- a balance, accurate to 0,1 mg
- a sample-encapsulating press
- aluminium pans, with covers
- where necessary, nitrogen gas supply, dry, analytical grade

B.3 Description of procedure

B.3.1 Sampling

A representative sample shall be taken from the cured epoxy resin primer. The sample shall weigh $10 \text{ mg} \pm 3 \text{ mg}$. The sample shall not have any PE adhesive residues.

B.3.2 Measurement

The DSC measurement consists of the following steps (runs):

- 1) Heat the sample from 25 °C to 110 °C ¹⁾ at a rate of 20 °C/min and then rapidly cool the sample to 25 °C with an isothermal phase of 1,5 min.
- 2) Heat the sample from 25 °C to 275 °C at a rate of 20 °C/min and then rapidly cool the sample to 25 °C with an isothermal phase of 1,5 min.
- 3) Heat the sample from 25 °C to a temperature that is roughly 40 °C above the glass transition temperature (point of inflection), at a rate of 20 °C/min and then rapidly cool the sample to 25 °C .

B.3.3 Evaluation

The first run serves to remove residual moisture on the sample.

During the second run, the glass transition temperature T_{g1} of the epoxy resin is determined in accordance with DIN EN ISO 21809-1. The peak occurring further along the curve characterises the uncured portion of the material. In the third run the glass transition temperature ΔT_{g2} of the cured portion of the same sample is determined.

The difference of the two glass transition temperatures should comply with the specifications of the raw material manufacturer.

1) In the case of epoxy resins with higher glass transition temperatures, sample conditioning shall be agreed with the raw material manufacturer.

Annex C (normative)

Cathodic disbondment (CD test)

C.1 General

This test consists of assessing the disbondment of the epoxy resin primer of damaged coatings when the steel substrate is exposed to cathodic polarization.

C.2 Apparatus

The test apparatus shall comprise the following components:

- potentiostat
- electrolytic cell with inlets for the necessary electrodes
- electrolyte: solution of 3 % NaCl
- equipment for heating the test set-up
- reference electrode (e.g. standard hydrogen electrode)
- auxiliary electrode (inert material, e.g. platinum wire)
- working electrode (coated pipe section to be tested)
- cutting instrument
- calliper gauge
- pH paper
- temperature measuring device (limit of error $< 1\text{ }^{\circ}\text{C}$)
- material for sealing the electrolytic cell
- drill bit, 6 mm

The ratio of the saturated area of the auxiliary electrode to the area of the working electrode (drilled hole) should be greater than 1.

Dimensions in millimetres

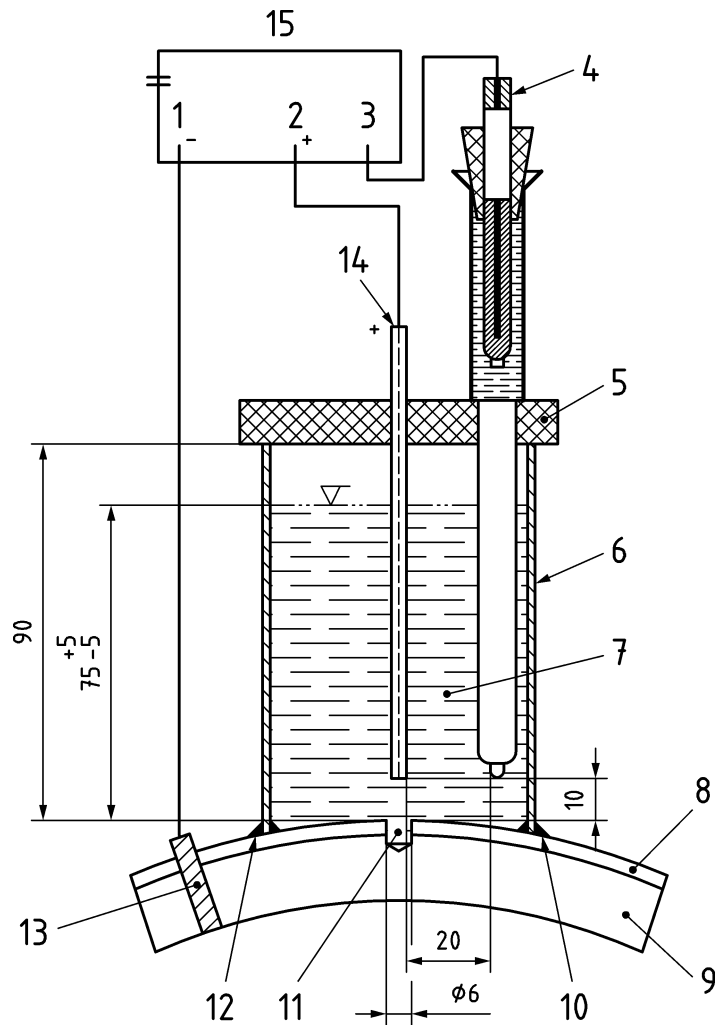
**Key**

- 1 Working electrode
- 2 Electrode (anode)
- 3 Electrode (reference)
- 4 Reference electrode
- 5 Plastic cover
- 6 Plastic tube (min. internal diameter 75 mm)
- 7 Electrolyte solution, ≥ 300 ml
- 8 Coating
- 9 Steel test piece
- 10 Sealing material
- 11 Defect
- 12 Sealing material
- 13 Electrode (cathode)
- 14 Platinum electrode, diameter 0,8 mm to 1,0 mm (anode)
- 15 Potentiostat

Figure C.1 — Electrolytic cell

C.3 Procedure

C.3.1 Sampling

Cut a section that is at least 80 mm × 80 mm from the coated pipe. The section should not be taken from the weld area. Drill a 6 mm hole through the coating down to the steel substrate. Then, centre the electrolyte cell with the electrodes around the hole. Using a suitable sealant, form a seal between the electrolyte cell and the polyethylene coating. For the test fill the cell with the electrolyte to a height of 75 mm ± 5 mm.

C.3.2 Measurement

Using the potentiostat, polarize the pipe section with the drilled hole to $U_H = -1\,260$ mV (at 23 °C), measured against a standard hydrogen electrode and, if necessary, heat it according to the required test conditions. Add distilled water to make up for loss of electrolyte during the test period.

Table C.1 — Commonly used electrodes and U_H with corrections

Reference electrode	Test potential at 25 °C V	Temperature coefficient mV/°C
Ag/AgCl in saturated KCl	-1,38	+1,0
Ag/AgCl/3 M KCl	-1,39	+1,0
Hg/Hg ₂ Cl ₂ in saturated KCl	-1,42	+0,65
Cu/CuSO ₄ (saturated)	-1,50	+0,97

C.3.3 Evaluation

After the test period, remove the cell, and rinse and dry the pipe section.

Using a suitable tool, chip off a sufficiently large area of the coating around the drilled hole. Take a total of eight measurements in 45° segments around the hole.

For each segment determine, to an accuracy of 0,5 mm, the maximum length of disbondment measured from the edge of the artificial defect to the edge of original adhered area

For system testing, calculate the arithmetic mean of three samples, and express the maximum length of disbondment expressed as the cathodic disbondment in mm.

NOTE Using a suitable cutting tool, cut out and then remove a square area of the coating the size of the sealed cylinder. The loss of adhesion is recognizable as a nearly circular area and is to be determined as follows. Divide the circle into eight segments.

Annex D (normative)

Peel strength

D.1 General

The peel strength test serves to check the correct application of the coating system of epoxy resin primer, PE adhesive layer and polyethylene layer, and, in the case of single-layer sintered coatings, the adhesion of the polyethylene to the steel substrate. The main criterion for three-layer coatings is the cohesive failure of the PE adhesive layer, i.e. the bond between the epoxy resin primer and the PE adhesive layer and that between the PE adhesive layer and the polyethylene layer are greater than the material strength of the PE adhesive used.

D.2 Apparatus

The test apparatus shall comprise the following components:

- a test assembly with force-proving instrument (possibly with recording capability);
- a means of pre-heating the sample material to be tested;
- a temperature measuring device.

The peel strength of the polyethylene coating shall be determined using the test assemblies shown in Figures D.1 and D.2 or equivalent test assemblies. Furthermore, a twin-blade saw or a suitable cutting device is required to prepare the samples.

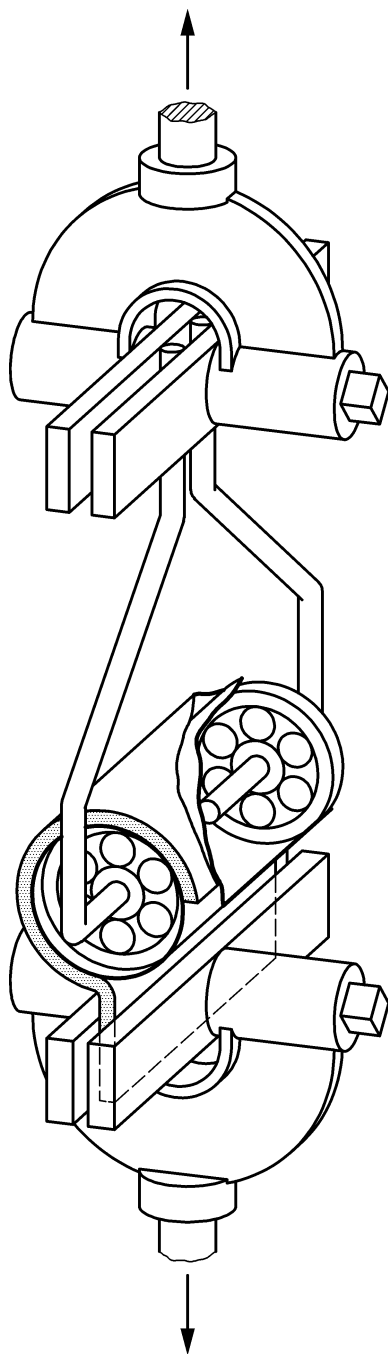
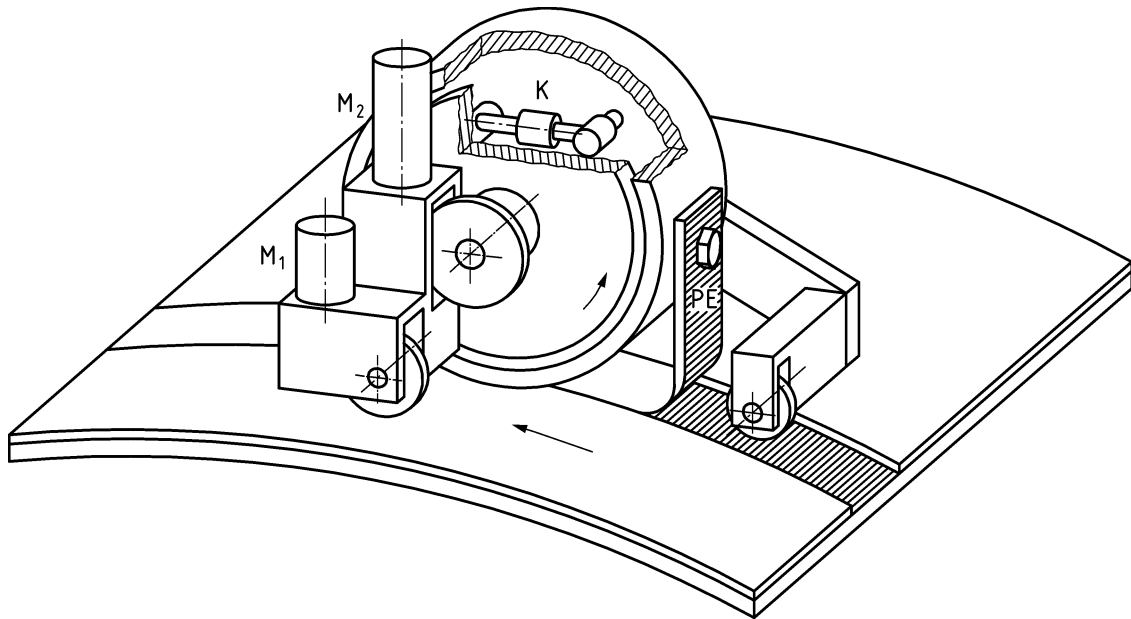

Figure D.1 — Type I test assembly for determining peel strength



Key

M ₁	Feed motor
M ₂	Peel motor
K	Dynamometer
PE	Coating strip

Figure D.2 — Type II test assembly for determining peel strength

D.3 Procedure

D.3.1 Sample preparation

Using a double-blade saw, for example, remove a strip of coating from the pipe or segment, in the circumferential direction, measuring a minimum of 20 mm to no more than 50 mm wide, cutting down to the steel substrate. Then, make another cut perpendicular to the axis of the previous cut to isolate the strip and lift a length of about 20 mm from the pipe. The sample shall be cut in the cold state.

D.3.2 Measurement

Test the peel strength of the polyethylene coating by pulling a 100 mm-long strip at a 90° angle to the pipe axis and at a rate of 10 mm/min. Record and document the force required to peel the strip.

For system testing, evaluations should be based on a continuously recorded force-time diagram.

The temperature tolerance shall be ± 5 °C for production control testing and ± 2 °C for system testing.

D.3.3 Evaluation

Determine the minimum value or (for sintered coatings) mean value from the recorded data, expressing these values in N/cm, disregarding the first 20 mm of the strip. If the polyethylene coating strip breaks during the test, the tensile force recorded at the time of the break applies.

Annex E (normative)

Continuity (holiday detection)

E.1 General

High-voltage testing is used to detect any defects (holidays) in the polyethylene coating. The dielectric strength of defect-free coatings is not tested.

E.2 Apparatus

The test is performed using commercially available spark testing equipment. Normally a metal brush or conductive rubber is used as the scanning electrode. The presence of defects is indicated by the sound of the spark or by a signal generated by the testing equipment.

E.3 Procedure

Set the voltage at 10 kV per mm of the minimum total coating thickness. The voltage should not exceed 25 kV. Pass the scanning electrode over the entire surface of the coating with the electrode touching the surface. A noticeable air gap will distort the result.

If there is a spark, mark the defective area.

Annex F (normative)

Elongation at break

F.1 General

Elongation at break shall be tested in accordance with DIN EN ISO 527-1 to DIN EN ISO 527-3.

F.2 Apparatus

The test shall be carried out using a tensile testing machine with which the force and displacement can be recorded.

F.3 Procedure

F.3.1 Sample preparation

Carry out the test on coating samples that are free from adhesive residue. For testing, the polyethylene layer may be applied without adhesive to make sampling easier. After sampling, the underside of the samples (surface which was previously in contact with the steel substrate) may be mechanically smoothed.

F.3.2 Measurement

Carry out testing at a temperature of $23\text{ °C} \pm 2\text{ °C}$ using type 1B, 5A or 5B test specimens (see DIN EN ISO 527-2:1996-07, Figure 1 and Figure A.2). Elongation is measured between two gauge marks within the test area.

The following test speeds apply:

Table F.1 — Test speeds

Test specimen type as in DIN EN ISO 527-2	Test speed as in DIN EN ISO 527-1 mm/min
1B	50
5A	25
5B	10

F.3.3 Evaluation

The elongation at break A_0 in % shall be determined using the following equation:

$$A_0 = \frac{L_1 - L_0}{L_0} \cdot 100$$

where

A_0 is the elongation at break in %;

L_0 is the initial distance between the gauge marks;

L_1 is the distance between the gauge marks at break.

The arithmetic mean of five results shall be determined.

Annex G (normative)

Measuring the melt mass-flow rate (MFR)

G.1 General

The MFR shall be determined in accordance with DIN EN ISO 1133-1.

G.2 Apparatus

The test apparatus specified in DIN EN ISO 1133-1 shall be used.

G.3 Procedure

G.3.1 Sampling

Virgin compound granules from the incoming goods inspection, as well as sections of the polyethylene coating shall be used as samples. Care shall be taken that coating samples are free of adhesives.

G.3.2 Measurement

Measurements shall be carried out in accordance with DIN EN ISO 1133-1, Procedure A, at 190 °C/2,16 kg (see Table 2).

G.3.3 Evaluation

Results shall be evaluated in accordance with E DIN EN ISO 1133-1:2010-06, 8.5.

Annex H (normative)

Impact resistance and low temperature impact resistance

H.1 General

Impact resistance is determined by means of a drop weight falling with a defined impact force.

The test shall be carried out at 23 °C and at the specified low temperatures.

H.2 Apparatus

The impact test shall be carried out using an apparatus with which the direction of fall is perpendicular to the pipe surface. The weight shall be guided to minimize friction. The face of the weight used is part of a hemispherical head with a diameter of 25 mm. The drop height shall be about 1 m. The impact energy should be $E = (5 \cdot \varphi)$ J per mm of coating thickness. The factor φ accounts for the curvature of the pipe. The impact energy may be reduced by the factor φ by changing the drop weight or reducing the drop height.

Table H.1 — Reduction factor φ as a function of pipe diameter

DN	φ
From DN 200	1,0
DN 65 to below DN 200	0,85
Below DN 65	0,70

H.3 Procedure

H.3.1 Test specimen preparation

The test shall be carried out on a pipe segment or a pipe section. The specimen shall be supported in such a manner that its elastic response is eliminated.

H.3.2 Procedure and evaluation

Ten impacts shall be carried out on the polyethylene coating, taking care that any protruding welds are avoided. The distance between two impacts should be at least 30 mm.

The polyethylene coating shall be checked for defects (holidays) as in Annex E using spark testing equipment. No holidays shall be detected.

Annex I (normative)

Indentation resistance

I.1 General

The test consists of measuring the indentation of a punch in the coating under fixed conditions of temperature and load.

I.2 Apparatus

The apparatus shall consist of a 250 g metal rod with an additional weight. A metal pin with a flat face that is $1,80 \text{ mm} \pm 0,05 \text{ mm}$ in diameter, giving an indentation area of $2,5 \text{ mm}^2$, shall be fitted centrally at the lower end of the rod. The total mass shall be 2,5 kg. The assembly shall produce a force of 10 N/mm^2 . Furthermore, a penetrometer with a dial gauge having an accuracy of 0,1 mm is needed. The test piece shall be conditioned, depending on the required test temperature.

I.3 Procedure

I.3.1 Test piece preparation

The test shall be performed on test pieces taken from the coating and which are no more than 2 mm thick and free from PE adhesive. If necessary, the bottom side of the test piece can be ground down to the desired thickness.

I.3.2 Procedure and evaluation

After conditioning the test piece for about 1 h, lower the indenter, without the additional weight, slowly and carefully onto the test piece. Set the zero value within 5 s. Then, attach the additional weight to the indenter and, after 24 h, read the depth of indentation indicated on the penetrometer scale.

Annex J (normative)

Specific electrical coating resistance

J.1 General

This test consists of measuring the reduction of the specific electrical coating resistance after the coating has been conditioned in an electrolyte.

J.2 Apparatus

The test is carried out either by bonding and sealing a plastic pipe segment to the surface of the sample or by placing a pipe section horizontally in a plastic container with lateral openings of suitable size. The gap between the container and pipe shall be closed with a suitable sealant.

The test medium shall be a 0,1 mol/l NaCl solution and should cover the pipe surface to a depth of about 100 mm. The surface of the counter electrode shall be at least 10 cm². Furthermore, a direct current supply having a minimum output voltage of 50 V and an ammeter and a voltmeter are necessary. The immersed test surface should be at least 0,03 m².

J.3 Procedure

J.3.1 Test piece preparation

Pipe segments or sections shall be used as test pieces. The test pieces shall be subjected to high-voltage continuity testing prior to this test.

J.3.2 Procedure and evaluation

The test piece shall be exposed to the test medium for 100 days at 23 °C.

For the purposes of measurement, the positive pole of the direct current source shall be connected to the steel substrate and the negative pole shall be connected to the counter electrode. During measurement the counter electrode shall be immersed in the test medium. The specific electrical coating resistance r_u shall be calculated from the following equation:

$$r_u = \frac{U \cdot S}{I}$$

where

r_u is the specific electrical coating resistance in Ωm^2 ;

U is the voltage between the counter electrode and the steel pipe in V;

S is the test area in m²;

I is the current passing through the coating in A.

The voltage is to be applied only at the time of measurement.

Annex K (normative)

UV resistance

K.1 General

To test resistance to UV ageing, polyethylene test samples are subjected to the continuous irradiation of a xenon lamp under given temperature and humidity conditions. Ageing is evaluated by assessing the changes in the material through the variation in its melt flow rate (MFR).

K.2 Apparatus

An apparatus shall be used with which the samples can be aged under the specified test conditions, and shall consist of an irradiation chamber equipped with a xenon lamp (see DIN EN ISO 4892-2, Method A).

K.3 Procedure

K.3.1 Sample preparation

The test shall be carried out on samples taken from the coating and which are free of PE adhesive residues. To this end the polyethylene coating can be applied without a PE adhesive layer to make sampling easier. The sample thickness shall be 1,8 mm to 2,5 mm and shall be uniform throughout.

K.3.2 Measurement

Measurements shall be carried out in accordance with DIN EN ISO 4892-2, Method A, Exposure Cycle no. 1. The provisions of DIN EN ISO 21809-1:2011-10, G.1.4.2, are to be taken into account.

Three MFR measurements shall be carried out in accordance with Annex G on the samples before (initial value) and after irradiation using a total radiant energy of 7 GJ/m².

K.3.3 Evaluation

The variation of the MFR after exposure, expressed as a percentage, shall be documented. The evaluation shall be carried out after exposure to a total radiant energy of 7 GJ/m².

Annex L (normative)

Thermal ageing resistance

L.1 General

To test resistance to thermal ageing, polyethylene test pieces are subjected to the effects of dry heat from a thermostatically controlled oven with air circulation. Ageing is evaluated by assessing the changes in the polyethylene through the variation in its melt flow rate (MFR).

L.2 Apparatus

The test is carried out after samples have been aged in a thermostatically controlled oven with air circulation capable of maintaining a test temperature within ± 2 °C.

L.3 Procedure

L.3.1 Sample preparation

The test shall be carried out on samples taken from the coating and which are free of PE adhesive residues. To this end the polyethylene coating can be applied without a PE adhesive layer to make sampling easier. The sample thickness shall be 1,8 mm to 2,5 mm and shall be uniform throughout.

L.3.2 Measurement

Samples shall be aged at a temperature of 100 °C for 100 days (2 400 h) for Type N coatings, and for 200 days (4 800 h) for Type S coatings. MFR measurements shall be carried out in accordance with Annex G on the samples before (initial value) and after every 800 h of ageing. In each case three measurements shall be taken.

L.3.3 Evaluation

The variation of the MFR after ageing, expressed as a percentage, shall be documented. The final evaluation shall be carried out after the ageing time specified above for each type of coating.