

# Steel tubes and fittings for onshore and offshore pipelines — External liquid applied epoxy and epoxy-modified coatings

The European Standard EN 10289:2002 has the status of a  
British Standard

ICS 23.040.99; 25.220.60

## National foreword

This British Standard is the official English language version of EN 10289:2002.

The UK participation in its preparation was entrusted by Technical Committee ISE/16, Protective coatings and linings of metal pipes and fittings, to Subcommittee ISE/16/-/11, External coatings for steel tubes and fittings, which has the responsibility to:

- aid enquirers to understand the text;
- present to the responsible international/European committee any enquiries on the interpretation, or proposals for change, and keep the UK interests informed;
- monitor related international and European developments and promulgate them in the UK.

A list of organizations represented on this subcommittee can be obtained on request to its secretary.

### Cross-references

The British Standards which implement international or European publications referred to in this document may be found in the *BSI Catalogue* under the section entitled “International Standards Correspondence Index”, or by using the “Search” facility of the *BSI Electronic Catalogue* or of British Standards Online.

This publication does not purport to include all the necessary provisions of a contract. Users are responsible for its correct application.

**Compliance with a British Standard does not of itself confer immunity from legal obligations.**

This British Standard, having been prepared under the direction of the Engineering Sector Policy and Strategy Committee, was published under the authority of the Standards Policy and Strategy Committee on 30 August 2002

### Summary of pages

This document comprises a front cover, an inside front cover, the EN title page, pages 2 to 41, and a back cover.

The BSI copyright date displayed in this document indicates when the document was last issued.

### Amendments issued since publication

Amd. No.	Date	Comments

EUROPEAN STANDARD

**EN 10289**

NORME EUROPÉENNE

EUROPÄISCHE NORM

August 2002

---

ICS 23.040.99; 25.220.60

English version

## Steel tubes and fittings for onshore and offshore pipelines - External liquid applied epoxy and epoxy-modified coatings

Tubes et raccords en acier pour canalisations enterrées et immergées - Revêtements externes en résine époxyde ou époxyde modifiée appliquée à l'état liquide

Stahlrohre und Formstücke für On- und Offshoreverlegte Rohrleitungen - Umhüllung (Außenbeschichtung) mit Epoxi- und epoxi-modifizierten Materialien

This European Standard was approved by CEN on 11 April 2002.

CEN members are bound to comply with the CEN/CENELEC Internal Regulations which stipulate the conditions for giving this European Standard the status of a national standard without any alteration. Up-to-date lists and bibliographical references concerning such national standards may be obtained on application to the Management Centre or to any CEN member.

This European Standard exists in three official versions (English, French, German). A version in any other language made by translation under the responsibility of a CEN member into its own language and notified to the Management Centre has the same status as the official versions.

CEN members are the national standards bodies of Austria, Belgium, Czech Republic, Denmark, Finland, France, Germany, Greece, Iceland, Ireland, Italy, Luxembourg, Malta, Netherlands, Norway, Portugal, Spain, Sweden, Switzerland and United Kingdom.



EUROPEAN COMMITTEE FOR STANDARDIZATION  
COMITÉ EUROPÉEN DE NORMALISATION  
EUROPÄISCHES KOMITEE FÜR NORMUNG

**Management Centre: rue de Stassart, 36 B-1050 Brussels**

## Contents

	page
Foreword.....	4
1 Scope .....	5
2 Normative references .....	5
3 Terms, definitions and symbols .....	6
3.1 Terms and definitions.....	6
3.2 Symbols .....	6
4 Coating materials .....	6
4.1 General.....	6
4.2 Technical specification .....	6
4.3 Packaging .....	8
4.4 Quality assurance .....	8
5 Information to be supplied by the purchaser .....	8
5.1 Mandatory .....	8
5.2 Options to be indicated by the purchaser .....	9
6 Application of the coating .....	9
6.1 Surface preparation .....	9
6.2 Composition of the coating .....	10
7 Requirements of the applied coating.....	11
7.1 General.....	11
7.2 Minimum dry thickness of the coating system .....	12
7.3 Hardness Shore "D".....	12
7.4 Appearance and continuity .....	12
7.5 Cut back at the ends .....	12
7.6 Holiday detection .....	12
7.7 Impact resistance.....	12
7.8 Adhesion test - Resistance to removal .....	13
7.9 Adhesion test - Pull-off method.....	13
7.10 Cathodic disbondment .....	13
7.11 Specific electrical insulation resistance.....	14
7.12 Adhesion test after immersion in tap water .....	14
7.13 resistance.....	14
7.14 Thermal ageing.....	14
7.15 Infra-red scan .....	15
8 Inspection .....	16
8.1 General.....	16
8.2 Documents.....	16
8.3 Sampling .....	16
8.4 Nature and frequency of testing and control .....	16
8.5 Retests .....	18
9 Repairs .....	18
10 Marking .....	19
11 Handling, transportation and storage.....	19
11.1 Handling.....	19
11.2 Transportation to the storage area .....	19
11.3 Storage.....	19

11.4	Loading of components for delivery.....	19
<b>Annex A</b>	<b>(normative) Dry thickness of the coating system.....</b>	<b>20</b>
A.1	General.....	20
A.2	Apparatus .....	20
A.3	Procedure .....	20
A.4	Results .....	20
<b>Annex B</b>	<b>(normative) Holiday detection test.....</b>	<b>21</b>
B.1	General.....	21
B.2	Apparatus .....	21
B.3	Procedure .....	21
B.4	Results .....	21
<b>Annex C</b>	<b>(normative) Impact test .....</b>	<b>22</b>
C.1	General.....	22
C.2	Apparatus .....	22
C.3	Procedure .....	22
C.4	Results .....	23
<b>Annex D</b>	<b>(normative) Adhesion test - Resistance to removal .....</b>	<b>24</b>
D.1	General.....	24
D.2	Apparatus .....	24
D.3	Procedure .....	24
D.4	Results .....	25
<b>Annex E</b>	<b>(normative) Cathodic disbondment test.....</b>	<b>26</b>
E.1	Principle.....	26
E.2	Apparatus .....	26
E.3	Sampling.....	27
E.4	Procedure .....	28
E.5	Investigation procedure .....	28
E.6	Results .....	28
<b>Annex F</b>	<b>(normative) Specific electrical insulation resistance test.....</b>	<b>32</b>
F.1	Test at ambient temperature ((23 ± 2) °C) .....	32
F.2	Test at maximum service temperature .....	33
<b>Annex G</b>	<b>(normative) Adhesion test after immersion in tap water .....</b>	<b>36</b>
G.1	General.....	36
G.2	Apparatus .....	36
G.3	Procedure .....	36
G.4	Results .....	36
<b>Annex H</b>	<b>(normative) Indentation test .....</b>	<b>37</b>
H.1	General.....	37
H.2	Apparatus .....	37
H.3	Procedure .....	37
H.4	Results .....	37
<b>Annex J</b>	<b>(normative) Thermal ageing .....</b>	<b>38</b>
J.1	General.....	38
J.2	Apparatus .....	38
J.3	Sampling.....	38
J.4	Procedure .....	38
J.5	Results .....	38
<b>Annex K</b>	<b>(normative) Types of inspection documents .....</b>	<b>39</b>
<b>Annex L</b>	<b>(informative) A-Deviation .....</b>	<b>40</b>
<b>Bibliography</b>	<b>.....</b>	<b>41</b>

## **Foreword**

This document EN 10289:2002 has been prepared by Technical Committee ECISS/TC 29 "Steel tubes and fittings for steel tubes", the secretariat of which is held by UNI.

This European Standard shall be given the status of a national standard, either by publication of an identical text or by endorsement, at the latest by February 2002, and conflicting national standards shall be withdrawn at the latest by February 2002.

The annexes A to K are normative.

Annex L is informative.

According to the CEN/CENELEC Internal Regulations, the national standards organizations of the following countries are bound to implement this European Standard: Austria, Belgium, Czech Republic, Denmark, Finland, France, Germany, Greece, Iceland, Ireland, Italy, Luxembourg, Malta, Netherlands, Norway, Portugal, Spain, Sweden, Switzerland and the United Kingdom.

## 1 Scope

This European Standard specifies the requirements of liquid applied external coating, epoxy (EP) and epoxy-modified (EP-MOD), for the corrosion protection of steel tubes and pipeline fittings.

The coating in this standard can be applied to longitudinally or spirally welded and to seamless steel tubes and fittings used for the construction of pipelines for conveying liquids or gases.

If the component has to be cold bent the coating shall be applied after bending unless otherwise approved by the purchaser.

The coating shall consist normally of one layer of liquid product, applied by brush or by spray airless technique. Other application methods can be recommended by the product manufacturer, in accordance with the kind of product.

This coating can be used for the protection of buried or submerged steel tubes for service at the following temperatures and with three thickness classes A (400 µm), B (800 µm) and C(1 500 µm) based on the following combination:

- type 1 : - 20 °C to 40 °C, thickness class A or B or C
- type 2 : - 20 °C to 60 °C, thickness class B or C
- type 3 : - 20 °C to 80 °C, thickness class C

Other temperatures can be agreed ; in this case, tests shall be carried out at the required temperature.

In this standard the word components is used for tubes and fittings.

Frequencies of tests on fittings shall be agreed by the parties at the ordering stage.

Components coated with these types of coatings may be further protected by means of cathodic protection.

## 2 Normative references

This European Standard incorporates by dated or undated reference, provisions from other publications. These normative references are cited at the appropriate places in the text, and the publications are listed hereafter. For dated references, subsequent amendments to or revisions of any of these publications apply to this European Standard only when incorporated in it by amendment or revision. For undated references the latest edition of the publication referred to applies (including amendments).

EN 10021, *General technical delivery requirements for steel and iron products.*

EN 24624, *Paints and varnishes - Pull-off test (ISO 4624:1978).*

EN ISO 868, *Plastics and ebonite - Determination of indentation hardness by means of a durometer (Shore hardness) (ISO 868:1985).*

EN ISO 2808, *Paints and varnishes - Determination of film thickness (ISO 2808:1997).*

EN ISO 8501-1, *Preparation of steel substrates before application of paints and related products - Visual assessment of surface cleanliness - Part 1: Rust grades and preparation grades of uncoated steel substrates and of steel substrates after overall removal of previous coatings (ISO 8501-1:1998).*

ISO 2815, *Paints and varnishes - Buchholz indentation test.*

### 3 Terms, definitions and symbols

#### 3.1 Terms and definitions

For the purposes of this European Standard, the following terms and definitions apply.

##### 3.1.1

**product manufacturer**

supplier of the two pack materials in a condition suitable for application to the product to be coated

##### 3.1.2

**coater**

responsible for applying the two pack materials to the components to be coated in accordance with the provisions of this European Standard or the special requirements given in the tender specification and in the order

##### 3.1.3

**purchaser**

company that buys the coated products

#### 3.2 Symbols

$R_z$  : roughness parameter (the average roughness from five successive evaluation areas defined in accordance with ISO 4287-1), expressed in microns ( $\mu\text{m}$ ) ;

$R_s$  : specific electrical insulation resistance of the coating, expressed in ohms square metres ( $\Omega\cdot\text{m}^2$ ).

### 4 Coating materials

#### 4.1 General

The two-pack coating is generally composed of a base (epoxy resin) and a curing agent.

The base (epoxy resin) and curing agent should have different colours allowing the verification of the correct mixing and checking the uniformity of the colour of the mixed product.

The coating is considered cured when it has attained the hardness recommended by the product manufacturer (see Table 1).

This standard calls for the use of substances and/or procedures that may be injurious to health if adequate precautions are not taken. It refers only to technical suitability and in no way absolves the user from statutory obligations relating to health and safety at any range.

#### 4.2 Technical specification

The technical specification drawn up by the product manufacturer shall contain as a minimum the information detailed in Table 1. Test methods shall be given for any test detailed in Table 1.

If required at the time of enquiry and/or order the following option can apply:

- Option 1 An infra-red scan obtained with a KBr standard disk or other method approved by the purchaser, shall be supplied as agreed for each pack (base, curing agent and cured product), so that the purchaser or the coater can compare it with the reference scan of the material supplied.

Other tests can be agreed between the parties at the time of enquiry and/or order.



Table 1 - Contents of data sheets and certificates

Elements	Technical data	Test certificate
Date of issue	X	X
Name of manufacturer	X	X
Name, use and type of product	X	X
Type of base (epoxy resin) and extender modification	X	X
Type of curing agent	X	X
Factory of origin		X
Batch or production lot number	a	X
Date of manufacture and use by date	a	X
Colour	a	X
Physical state of the delivered product	a	X
Methods of application	X	
Solids by volume	X	
Solids by weight	X	X
Theoretical coverage per m <sup>2</sup> for nominal thickness	X	
Size of container	a	X
Shelf life	a	X
Storage conditions	X	
Pot-life	X	
Surface preparation	X	
Recommended instructions for application	X	
Recommended repair material(s)	X	
Mixing instructions	X	
Recommended dry film thickness	X	
Typical thickness applicable in one layer	X	
Minimum and maximum overcoating time	X	
Range of tube service temperature	X	
Range of application temperature (ambient, tube and product) and humidity	X	
Specific curing - Requirements	X	
Shore "D" hardness at (23 ± 2) °C	X	
Time at (23 ± 2) °C to achieve Shore "D" hardness at curing	X	
Time at (23 ± 2) °C at Shore "D" hardness before handling	X	
Viscosity	b	X
Density	X <sup>b</sup>	X <sup>a</sup>
Impact resistance	X	
Pull-off test adhesion at (23 ± 2) °C	X	
Cathodic disbonding at (23 ± 2) °C	X	
Specific electrical insulation resistance	X	
Thermal ageing	X	
Test methods described in the present standard shall be used. In any case test methods used shall be mentioned for any tests. The acceptable limits shall be mentioned in the test certificate.		
<sup>a</sup> Required for the base (epoxy resin) and curing agents.		
<sup>b</sup> Required for the base (epoxy resin), curing agent and for the mixed product.		

### **4.3 Packaging**

All materials supplied for coating operations shall be suitably marked giving, as a minimum, the following details:

- product manufacturer's name;
- name of material;
- application method;
- batch number;
- date of manufacture and use-by date;
- recommended storage conditions;
- colour of the material.

### **4.4 Quality assurance**

The product manufacturer shall carry out quality inspection so that he guarantees the consistent quality of the products and maintains the properties listed in Table 1.

If the product manufacturer has a quality control service approved by the coater, he shall provide a test certificate, on the understanding that the record of the results of his inspection is made available to the coater for checking where necessary. The inspection shall be carried out on every batch of material.

For specific requirements the purchaser can ask for additional information at the time of enquiry and order.

## **5 Information to be supplied by the purchaser**

### **5.1 Mandatory**

The purchaser shall state in his enquiry and order the following minimum information:

- tubes and components coated in accordance with this European Standard shall be designated by reference to this standard followed by the base material, the thickness class and the service temperature of the coating. If applicable, the reference to the standard for the component to which the coating is applied shall be added to this designation;

EXAMPLE: 5 000 meters of tubes - EN 10224 of 406, 4-4, 0  
external coating EN 10289, EP, class A, Type 3

- base material (EP or EP-MOD);
- thickness class of the coating A, B or C (see 7.2);
- service temperature Type (1, 2 or 3);
- cut back at the ends (for fittings);
- maximum number and dimension of repairs (not including repairs due to destructive tests).

The components coated in accordance with this European Standard shall be designated by:

- the reference to this standard;
- the base material (EP or EP-MOD);
- the thickness class of the coating (A, B or C);
- the service temperature Type (1, 2 or 3).

## 5.2 Options to be indicated by the purchaser

- 1 Infra-red scan (see 4.2) ;
- 2 Cut back at the ends for tubes (see 7.5);
- 3 Adhesion test - Pull-off method (see 7.9);
- 4 Cathodic disbondment (see 7.10);
- 5 Specific electrical insulation resistance (see 7.11);
- 6 Adhesion test after immersion in tap water (see 7.12);
- 7 Indentation resistance (see 7.13);
- 8 Thermal ageing (see 7.14);
- 9 Type of inspection documents required, if different to the ones in clause 8 (see 8.2.2);
- 10 Other scheme of procedure qualification (see Table 5).

## 6 Application of the coating

### 6.1 Surface preparation

**6.1.1** Prior to abrasive blast cleaning, the steel surface shall be dry and free from contamination (oil, grease, temporary corrosion protection, etc.) and surface defects (slivers, laminations, etc.) detrimental to the surface or to the adhesion of the coating.

**6.1.2** Components shall be abrasive blast cleaned. The degree of cleanliness shall be Sa 2 ½ in accordance with EN ISO 8501-1.

The blast cleaned surface shall have a roughness  $R_z$  between 50 µm and 90 µm, as measured in accordance with ISO 4287-1.

**6.1.3** After blast cleaning, the surface of the components shall be inspected. All slivers, laminations, weld spatter and other surface imperfections made visible by the blast cleaning process shall be removed.

After removal of these defects, the residual thickness of components shall satisfy the minimum tolerance requirements specified by the relevant standard. All treated areas greater than 10 cm<sup>2</sup> shall be prepared to provide a profile to satisfy the provisions of 6.1.

**6.1.4** Components shall be maintained at least 3 °C above the dew point temperature prior to coating.

**6.1.5** Contaminants (e.g. residual abrasive dust) shall be removed prior to coating.

Chemical treatment of the steel may be used in addition to abrasive blast cleaning, by agreement between the purchaser and the coater.

**6.1.6** The temperature and holding time of the component prior to coating shall not result in oxidation of its surface, detrimental to the good quality and adhesion of the coating.

At the time of application, the temperature range on the surface of the component to be coated shall be determined in agreement with the manufacturer of the product.

The temperature of the components shall be monitored using suitable means in order to make sure that the application conditions are fully satisfied.

## **6.2 Composition of the coating**

### **6.2.1 General**

The coating shall be applied in accordance with the established procedure.

The constituent material data sheets shall contain the items required in Table 1.

### **6.2.2 Mixing**

Base (epoxy resin) and curing agent shall be supplied in separate containers.

The contents of each container shall be stirred or agitated to an homogeneous state before any is withdrawn.

Base (epoxy resin) and curing agent shall be thoroughly mixed in the proportions specified by the product manufacturer.

When the two pack materials are supplied in different colours, evidence of complete mixing is indicated when a uniform colour is achieved without any "streaking".

For twin feed airless application, appropriate monitoring equipment shall be used to ensure correct metering of the two pack materials.

The quantity of material made up at one time shall not exceed that which can be used within the pot life stated by the product manufacturer or that necessary to ensure complete coverage of the area to be coated.

### **6.2.3 General application procedure**

A layer of liquid applied coating shall be applied to the blast cleaned components using the method and equipment recommended by the product manufacturer.

The coating shall be uniform.

If a second layer is required to reach the prescribed thickness, this shall be applied in accordance with the overcoating time prescribed by the product manufacturer.

Particular attention shall be paid to the recommended dry film thickness.

The wet film thickness shall be measured in accordance with EN ISO 2808.

If pre-heating of the base (epoxy resin) and/or the curing agent is required prior to mixing and application, this shall be carried out in accordance with the product manufacturer's procedure.

If post-heating of the coating after application is required, this shall also be carried out in accordance with the product manufacturer's procedure.

No thinner shall be used unless recommended by the product manufacturer. Tools and equipment shall be cleaned using only such solvents as are recommended by the product manufacturer.

Particular care shall be taken in the handling of the components before the coating has reached the minimum value of hardness recommended by the manufacturer.

#### **6.2.4 Field and shop application procedure**

In the field, coating shall not be applied during rain, fog or mist, or when there is free moisture on the prepared surface.

The coating operation shall be suspended when the metal temperature falls to within 3 °C of the dew point, or is less than 5 °C and/or when the relative humidity is higher than 90 %.

During adverse weather conditions, coating may still be carried out if the local environment is controlled to avoid the unacceptable conditions, above specified. This may be achieved by the erection of protective canopies and the use of heaters and dehumidifiers to the satisfaction of the purchaser.

Coating shall always be applied in accordance with the product manufacturer's instruction.

Components shall not be backfilled until the coating is cured in accordance with the hardness recommended by the product manufacturer (see Table 1).

## **7 Requirements of the applied coating**

### **7.1 General**

The required properties of the applied coatings are given below:

- minimum dry thickness of the coating system;
- hardness Shore "D";
- appearance and continuity;
- infra-red scan;
- cut back at the ends;
- holiday detection;
- impact resistance;
- adhesion test - resistance to removal;
- adhesion test - pull-off method;
- cathodic disbondment;
- specific electrical insulation resistance;
- adhesion test after immersion in tap water;
- indentation resistance;
- thermal ageing.

Other properties can be specified at the time of enquiry and order.

A summary of the required properties is given in Table 4.

## 7.2 Minimum dry thickness of the coating system

Coating thickness shall be measured in accordance with the method defined in annex A.

Unless otherwise agreed by the purchaser, the minimum dry thickness of the coating system at any point shall correspond to the following value depending on the class (A, B or C):

— 400 µm	class A
— 800 µm	class B
— 1 500 µm	class C

## 7.3 Hardness Shore "D"

This test shall be carried out in accordance with the method defined in EN ISO 868.

The test can be carried out also on 800 µm thickness coating.

The acceptance criteria shall be stated on the hardness value set by the product manufacturer.

## 7.4 Appearance and continuity

The appearance and continuity of the coating shall be inspected visually over the total length of all components.

The coating shall be of uniform colour, appearance and be free of holidays, defects and laminations detrimental to the quality of the coating.

## 7.5 Cut back at the ends

The length of the cut back for tubes shall be  $(150 \pm 20)$  mm.

Other length of cut back can be specified.

For fittings cut back shall be specified in the order.

When removing the coating, the surface of the component shall not be damaged.

## 7.6 Holiday detection

Holiday detection shall be carried out in accordance with the method defined in annex B with a minimum voltage of 8 V per µm of specified minimum thickness with a maximum of 20 kV.

Detected defects, e.g. holidays, porosity or other damages shall be repaired in accordance with clause 9.

The maximum number and dimensions of repairs permitted shall be defined by the purchaser (see 5.1).

## 7.7 Impact resistance

The maximum impact energy, in Joules, which does not give rise to perforation when detected in accordance with the method described in annex B, shall be determined in accordance with the method defined in annex C.

For the coating classes B and C, the minimum impact energy, in Joules, shall correspond to  $5 J \times k$  for each millimetre of coating thickness at  $(23 \pm 2) ^\circ\text{C}$  and  $3 J \times k$  for each millimetre of coating thickness at  $(-5 \pm 3) ^\circ\text{C}$ . The values of  $k$  are given in Table 2.

For the coating class A the minimum impact energy, in Joules, shall correspond to  $1,5 J$  at  $(23 \pm 2) ^\circ\text{C}$  and  $3 J$  at  $(-5 \pm 3) ^\circ\text{C}$

**Table 2 - Correction factor**

Pipe diameter mm	$k$
$D > 219,1$	1,00
$76,1 < D \leq 219,1$	0,85
$D \leq 76,1$	0,70

This test shall be carried out on components representative of the production or on tubes of diameter between 100 mm and 150 mm.

### 7.8 Adhesion test - Resistance to removal

The resistance of the coating to removal shall be determined in accordance with the requirements of annex D.

The adhesion of the coating shall satisfy the requirements of rating 2 at  $(23 \pm 2) ^\circ\text{C}$ .

Results shall be given for information at the maximum service temperature.

### 7.9 Adhesion test - Pull-off method

The minimum pull-off adhesion shall be determined in accordance with the method defined in EN 24624 (cutting around dolly) and shall correspond to 7 MPa at  $(23 \pm 2) ^\circ\text{C}$ .

An adhesive rupture at the interface steel-coating shall be considered a failure.

Results shall be given for information at the maximum service temperature.

### 7.10 Cathodic disbondment

This test shall be carried out in accordance with the method defined in annex E.

The cathodic disbondment shall be determined as being the radius from the artificial defect to the edge of the area of coating easily removed.

The average radius of disbondment shall be determined over eight measurements and shall be equal to or less than 6 mm and the maximum radius of disbondment shall be equal or less than 8 mm, after one of the following testing regimes:

- 2 days at  $(60 \pm 2) ^\circ\text{C}$ ;
- 28 days at  $(23 \pm 2) ^\circ\text{C}$ .

Other testing regimes may be used by agreement.

**7.11 Specific electrical insulation resistance**

The specific electrical resistance of the coating,  $R_s$ , shall be measured in accordance with the method defined in annex F, after being immersed for 100 days. The coating shall satisfy the following requirements:

- 1) the  $R_s$  value shall be not less than the values given in Table 3 ;
- 2) when the  $R_s$  value after 70 days remains only a power of ten above the permissible 100 days value, then the ratio:

$$\alpha = \frac{R_s (100 \text{ days})}{R_s (70 \text{ days})} \geq 0,8$$

**Table 3 : Specific electrical insulation resistance**

$R_s$ value ( $\Omega \cdot m^2$ ) after 100 days at (23 ± 2) °C		$R_s$ value ( $\Omega \cdot m^2$ ) after 30 days at maximum service temperature ± 2 °C	
Class B	Class C	Class B	Class C
10 <sup>6</sup>	10 <sup>7</sup>	10 <sup>4</sup>	10 <sup>4</sup>

For coating class A, the requirements have to be agreed between the purchaser and product manufacturer.

**7.12 Adhesion test after immersion in tap water**

This test shall be carried out in accordance with the method defined in annex G.

Results shall be given for information.

**7.13 Indentation resistance**

Indentation resistance shall be determined by testing in accordance with the method defined in annex H.

The test shall be carried out on a coating thickness in the range of 400 µm to 600 µm for class A , in the range of 800 µm to 1 200 µm for class B and in the range of 1 500 to 2 000 for class C.

The test shall be carried out at (23 ± 2) °C and at the maximum tube service temperature ± 2 °C.

The indentation shall not be more than 0,2 mm at (23 ± 2) °C and 30 % of the initial measured coating thickness at the maximum service temperature ± 2 °C.

**7.14 Thermal ageing**

Thermal ageing shall be determined by testing in accordance with the method defined in annex J after exposure to the following conditions:

- type 1 : 100 days at (60 ± 2) °C ;
- type 2 : 100 days at (80 ± 2) °C ;
- type 3 : 100 days at (100 ± 2) °C.



Results shall be given for information.

### 7.15 Infra-red scan

An infra-red scan obtained with a KBr standard disk or other method approved by the purchaser, shall be carried out on the cured coating.

The acceptance criteria shall be based on the comparison with the reference scan supplied by the product manufacturer.

**Table 4 - Summary of the required properties**

Handling temperature of the coating	Type 1 : - 20 °C to + 40 °C Type 2 and 3 : - 20 °C to + 60 °C
Service temperature	Type 1 : - 20 °C to 40 °C for thickness class A or B or C Type 2 : - 20 °C to 60 °C for thickness class B or C Type 3 : - 20 °C to 80 °C for thickness class C

Properties	Requirements	Subclause	
Dry thickness of the coating system	Class A : 400 µm minimum Class B : 800 µm minimum Class C : 1 500 µm minimum	7.2	
Hardness Shore "D"	Specified by the manufacturer	7.3	
Appearance and continuity	Uniform colour, smooth appearance and free from defects	7.4	
Cut back	(150 ± 20) mm	7.5	
Holiday detection	Free from holiday	7.6	
Impact resistance	(23 ± 2) °C	7.7	
	for class A only		(- 5 ± 3) °C
	for classes B and C		
Adhesion test Resistance to removal	1,5 J	7.8	
	5 J × k × mm (mm of coating thickness)		1,0 J
Adhesion test Pull-off method	3 J × k × mm (mm of coating thickness)	7.9	
	(23 ± 2) °C		maximum service temperature ± 2 °C
Cathodic disbondment	≤ rating 2	7.10	
	7 MPa		Results for information
Specific electrical insulation resistance	Average	7.11	
	≤ 6 mm		Maximum
Adhesion test after immersion in tap water	≤ 8 mm	7.12	
Indentation resistance	Minimum $R_s$ after set number of days at constant temperature	7.13	
	(23 ± 2) °C		maximum service temperature ± 2 °C
Thermal Ageing	≤ 0,2 mm	7.14	
	≤ 30 % of initial measured thickness		Results for information
Infra-red scan	Acceptable comparison with reference scan	7.15	

## **8 Inspection**

### **8.1 General**

Testing shall be carried out in accordance with Table 5 when the coating has attained the hardness recommended by the product manufacturer.

### **8.2 Documents**

Inspection operations shall be carried out by the coater if agreed at the time of enquiry and order.

A representative appointed by the purchaser may witness these operations (see EN 10021).

If inspection operations are performed the results shall be recorded by the coater and made available to the representative of the purchaser.

#### **8.2.1 Standard**

A certificate 3.1.B in accordance with annex K shall be issued, if not otherwise requested by the purchaser.

#### **8.2.2 Special**

Option 9

A certificate 3.1.A or 3.1.C in accordance with annex K shall be issued.

Inspection operations shall be carried out by the coater as agreed at the time of enquiry and order.

### **8.3 Sampling**

The purchaser's representative or, the coater's inspection representative shall select the components on which the specified tests shall be carried out.

The test pieces for destructive testing should be taken, if possible, from the ends of the tubes. Samples and the test tubes shall be marked in order to be fully identifiable.

### **8.4 Nature and frequency of testing and control**

The nature and the minimum frequency of the testing and control shall be in accordance with Table 5.

Table 5 - Nature and frequency of testing and control

Properties	Subclause	Test method	Minimum production control	System and applicator approval <sup>a b</sup>
Surface condition before blast cleaning	6.1	Visual	Every component	3 components
Dimension, shape and properties of blast cleaning products and checking of the blast cleaning process	6.1	-	Twice per shift <sup>c</sup>	3 components
Roughness of the blast cleaned surface	6.1	ISO 4287-1	Once per shift <sup>c</sup>	3 components
Visual condition of the blast cleaned surface	6.1	Visual	Every component	3 components
Temperature of pre-heating before coating, if necessary	6.2	-	Continuously <sup>c</sup>	3 components
Temperature of post-heating, after coating, if necessary	6.2	-	Continuously <sup>c</sup>	3 components
Room temperature and humidity	6.2	-	Continuously <sup>c</sup>	3 components
Wet thickness of the coating system	6.2	EN ISO 2808	<sup>d</sup>	3 components
Dry thickness of the coating system	7.2	annex A	4 per shift <sup>c</sup>	3 components
Hardness Shore "D"	7.3	EN ISO 868	4 per shift	3 components
Appearance and continuity	7.4	Visual	Every component	3 components
Cut back	7.5	Visual	Every component	3 components
Holiday detection	7.6	annex B	Every component	3 components
Impact resistance at (-5 ± 3) °C and at (23 ± 2) °C	7.7	annex C	-	3 samples <sup>i</sup>
Adhesion test - Resistance to removal	7.8	annex D	Once per shift at (23 ± 2) °C once per week at max. temperature <sup>c</sup>	3 components
Adhesion Test - Pull-off method <sup>f</sup>	7.9	EN 24624	<sup>g</sup>	3 panels
Cathodic disbondment <sup>f h</sup>	7.10	annex E	<sup>g i</sup>	3 components
Specific electrical insulation resistance <sup>f h</sup>	7.11	annex F	<sup>g i</sup>	3 tubes
Adhesion test after immersion in tap water <sup>f h</sup>	7.12	annex G	<sup>g</sup>	3 panels
Indentation resistance <sup>f</sup>	7.13	annex H	<sup>g i</sup>	3 tubes
Thermal ageing <sup>f h</sup>	7.14	annex J	<sup>g i</sup>	3 tubes
Infra-red scan <sup>f</sup>	7.15	-	<sup>g</sup>	3 components

<sup>a</sup> All tests detailed shall be undertaken at least every 3 years for the same system, material and significant technical process. The system and applicator approval may be combined with a coating production run.

<sup>b</sup> Option 10

Other schemes of qualification may be requested by the purchaser.

<sup>c</sup> If the process is discontinuous this test shall be carried out on every component.

<sup>d</sup> The test shall be carried out as follows :

automatic plant : 1 tube every 5, or each fitting ;

manual application : 3 times per component.

<sup>e</sup> Any component from the beginning to the end of production may be used for this test.

<sup>f</sup> Option to be indicated by the purchaser.

<sup>g</sup> The test and their frequency shall be defined at the time of the inquiry and order.

<sup>h</sup> The delivery of tubes can be undertaken prior to the completion of the test.

<sup>i</sup> By agreement the test can be carried out on panels or samples coated at the same time and in the same way as production. This is permissible if qualification trials have been carried out both on panels and components.

## **8.5 Retests**

**8.5.1** Tests results which are unsatisfactory and not attributable to the quality of the coating could result from:

- a defective sampling of the test piece;
- defective assembling or abnormal operation of the testing machine.

In such cases, the test shall be disregarded and repeated.

**8.5.2** During production control tests, if the results of one or more tests are incorrect or inadequate, the following steps shall be taken:

- the tubes which are deemed defective shall be taken back by the coater;
- the test that failed shall be repeated on the two tubes before and after the tube that failed.

If the results from both tubes are satisfactory, the coating shall be considered acceptable. If not, the coating shall be considered unacceptable.

The coater shall undertake the necessary measures to provide coated tubes that comply with the specification.

If the coating is rejected, the coater shall recoat tubes in accordance with a procedure approved by all parties and present the recoated tube for acceptance again.

## **9 Repairs**

Coating defects accepted in accordance to 7.6 and those resulting from destructive tests 7.8 and 7.9, shall be repaired.

The coating materials that can be used for repairing defects shall satisfy two conditions:

- be suitable for protecting onshore and offshore pipelines in the required service conditions (e.g. service temperature);
- be compatible with the coating applied previously.

The repair system, the repair materials and the application conditions for repair materials shall be those defined in the manufacturer's technical data sheet and/or approved by the purchaser.

The area of the porosity and small areas of damaged coating, together with the adjacent coating, shall be thoroughly abraded with a wire brush to remove all corrosion products.

All large damaged areas shall be cleaned by a blast cleaning technique; the coating around the area to be repaired shall be lightly abraded for at least 10 mm from the perimeter of the exposed substrate.

Where the metal substrate is visible, it shall be cleaned in accordance with EN ISO 8501-1, Sa 2 ½ degree.

All dust, corrosion products and loose coating shall be removed.

The surface of the component shall be maintained in a dry condition during application of the repair material.

The completed repair shall satisfy the values specified in the manufacturer's technical data sheet.

After curing and prior to delivering or ditching, all repaired areas shall be holiday detected in accordance with annex B.

## 10 Marking

Marking shall be undertaken on each component and shall include the following:

- identification;
- code or name of the producer of the steel (if known);
- applicator code, if it differs from the preceding code;
- reference to the steel standard (if known);
- reference to this European Standard followed by the base material, the thickness class and the service temperature type.

Marking shall be carried out using a suitable method such as stencil painting or printing, making possible legible and indelible identification, using durable materials compatible with the later use of the components.

## 11 Handling, transportation and storage

### 11.1 Handling

Coated components shall be handled without causing damage to the ends of the components or to the coating. The direct use of steel ropes or slings or of any equipment which could damage the coating and the ends shall be prohibited.

### 11.2 Transportation to the storage area

During transportation to the storage area at the coater's works, the coater shall take all relevant precautions to avoid damage to the components and to the coating.

### 11.3 Storage

Storage shall be carried out so that the coating does not deteriorate. In particular, stacks of components which are intended to be stored for a long period shall be protected against the action of ultraviolet irradiation and from heat.

### 11.4 Loading of components for delivery

During loading of components in the factory or in the field, the coater shall take the reasonable precautions to make sure that loading is carried out correctly in order to avoid damage to the component or to the coating during transportation.

The coater is responsible for the supply of correctly coated components as detailed in the tender documentation.

## **Annex A** (normative)

### **Dry thickness of the coating system**

#### **A.1 General**

The test consists of measuring, by means of a non-destructive process, the thickness of the applied coating.

#### **A.2 Apparatus**

A magnetic, electromagnetic or ultrasonic measuring instrument with  $\pm 3$  % accuracy shall be used. The instrument shall be calibrated with respect to the blast cleaned steel when possible, on which the coating is applied in the range of thickness of the coating to be tested. Otherwise calibration with respect to the steel can be made. In any case it shall be calibrated frequently.

#### **A.3 Procedure**

On each component to be tested, at least 12 measurements shall be carried out.

The measurements points shall be distributed along four equally spaced longitudinal lines at the intersection with three equally spaced circumferential lines and at a distance of at least 200 mm from the end of the coating.

#### **A.4 Results**

All the measured values shall be recorded.

## **Annex B** (normative)

### **Holiday detection test**

#### **B.1 General**

The test consists of looking for any porosity in the coating using a scanning electrode energized by a high-arc-voltage.

Defects shall be detected by a spark occurring between the steel of the component and the electrode at the defect, accompanied by a sound and light signal provided by the holiday detector.

#### **B.2 Apparatus**

The apparatus shall consist of:

- adjustable high-voltage holiday detector, equipped with a sound and light signal;
- scanning electrode in the form of a metal brush, or coil spring with continuous spirals, or conductive rubber conforming to the shape of the components;
- conductors which are used to connect the component to an earth electrode.

#### **B.3 Procedure**

This test shall only be undertaken on a coating free from surface moisture.

The instrument and earth shall be connected to the coated component, completing the circuit, switched on, and the scanning electrode passed over the surface of the coating to be inspected with a continuous movement. The rate of the relative movement of the electrode shall not be limited but it shall be demonstrated that a defect of a diameter of one millimetre can be detected.

At the time of the test, the minimum voltage shall be in accordance with the coating product standard.

#### **B.4 Results**

The component identification and the number of holidays shall be recorded.

## Annex C (normative)

### Impact test

#### C.1 General

The test consists of verifying the strength of the coating by the impact of a punch of defined shape falling directly onto the coating from a fixed height and at a fixed temperature.

#### C.2 Apparatus

The apparatus shall consist of a drop weight testing machine comprising:

- a straight guide made of steel, aluminium or plastic, rigid and non-deformable, of inside diameter between 40 mm and 60 mm, of length at least 1,30 m and incorporating a smooth and even inside surface. The guide shall be provided with:
  - a support and levelling devices (for example, two spirit levels for the horizontal plane and a plumb line for the vertical plane);
  - a graduated rod which makes it possible to determine the drop height with an accuracy of 5 mm.

Other guides may be used by agreement;

- a hard steel punch, with a hemispherical head, free from notches, porosity or other surface irregularities and with a diameter of 25 mm. A small metal rod of diameter 6 mm shall be fixed perpendicular to the flat face of the head and in its centre, where this rod shall be long enough to hold the additional weights required for the tests. The punch shall be equipped with a suitable system for raising to the required height; the accuracy of the mass of this assembly shall be  $(1 \pm 0,005)$  kg;
- a sufficient number of additional weights, formed by metal discs (preferably made of stainless steel) of outside diameter approximately 24 mm and incorporating a central hole of diameter 6,5 mm; the mass of each disc shall be known with an accuracy of  $\pm 5$  g.

#### C.3 Procedure

The coated tube shall be placed on a rigid, and stable, horizontal support, and if necessary, the tube interior shall be supported to reduce its elastic response.

Before carrying out an impact test, the holiday and detection test shall be undertaken (see annex B) to identify the defective points and to avoid making the impact at these locations ; if the number of faults found is too high, another coated test piece shall be taken.

For each point of impact, the drop weight testing machine shall be arranged perpendicular to the coating surface so that the loaded punch can fall freely without friction or resistance.

Ten impacts shall be carried out allowing the weight corresponding to the energy laid down in 7.7 to fall from a height of one meter. The points of impact shall be selected so as to avoid, as much as possible, any protruding welds. Furthermore, the distance from the points of impact to the end of the tube shall be at least  $1,5 D$  ( $D$  is the outside diameter of the pipe in millimetres) and at least 50 mm between the axes of the impacts.



The holiday detection test shall then be undertaken at each location (see annex B).

Depending on the result obtained (number of perforations obtained from the ten impacts made), a further series of ten is carried out increasing or decreasing weights, so as to be able to plot a curve of the number of perforations with respect to the impact energy.

The hard steel punch shall be checked every 30 impacts. If damaged, it shall be changed.

#### **C.4 Results**

From the curve obtained, determine the maximum impact energy, in Joules, which does not give rise to perforation detected in accordance with the method described in annex B.

## Annex D (normative)

### Adhesion test - Resistance to removal

#### D.1 General

The test consists of determining the adhesion of the coating by a destructive process.

#### D.2 Apparatus

Apparatus shall consist of:

- a utility knife (e.g. with a stiff straight blade);
- a steel rule, if required;
- a steel rod, if required;
- an oven.

#### D.3 Procedure

The test area shall consist of any coated area on the component or test piece that is free from all defects and with the correct dry film thickness.

**D.3.1** Using a sharp-bladed utility knife against a steel rule if necessary, straight 30 mm to 50 mm cuts shall be made in the coating through to the metal surface to form an X with an angle of approximately 30° at the intersection point.

**D.3.2** The point of the utility knife shall be inserted horizontally (i.e. the flat of the blade) under the coating at the point of intersection of the cuts such that the blade point is at the metal surface.

**D.3.3** A levering action against a fulcrum (such as steel rod) shall be used to force the flat point of the blade up from the metal surface describing a single, vertical (i.e. at 90° to the surface) motion in an attempt to prise the coating off.

**D.3.4** The same procedure (from D.3.1 to D.3.3) shall be applied to test the coating at the maximum service temperature.

A sample shall be conditioned in an oven for 4 hours.

Immediately after the removal from the oven, an adhesion test shall be carried out in accordance with the procedure mentioned above.

Then the sample shall be maintained at  $(23 \pm 2)$  °C for 24 hours and the adhesion test shall be repeated.

## D.4 Results

The adhesion of the coating shall be determined by the following rating system:

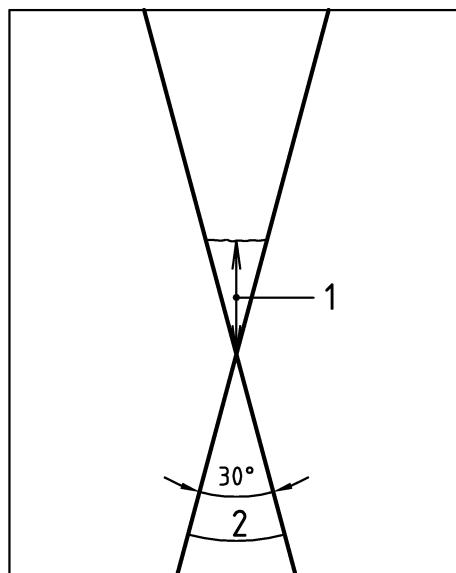

### Key

1 Adhesive loss of coating (rating 1 to 5)

**Rating 1** : No removal of coating other than that caused by insertion of the flat point of the knife blade at the intersection point (nominally less than 1 mm).

**Rating 2** : Not more than 2 mm of adhesive loss of coating from the metal surface.

**Rating 3** : Not more than 3 mm of adhesive loss of coating from the metal surface.

**Rating 4** : Not more than 5 mm of adhesive loss of coating from the metal surface.

**Rating 5** : More than 5 mm of adhesive loss of coating from the metal surface.

2 Cuts

**Figure D.1 – Rating system of the coating adhesion**

The rating of the coating adhesion is determined by adhesive failure. Limited cohesive rupture within the coating shall be considered a pass, if there is satisfactory adhesion.

Cohesive rupture caused by excessive interface or cross-section porosity leaving a noticeable "honeycomb" structure on the specimen surface shall constitute a fail.

For the test at the maximum operating temperature the adhesive loss in millimetres, measured vertically from the intersection point of X-cuts to the adherent coating, not along the X-cuts, shall be recorded (see Figure D.1).

## Annex E (normative)

### Cathodic disbondment test

#### E.1 Principle

The test consists of assessing the resistance to disbondment of damage to the coatings when exposed to cathodic polarisation.

The test shall be performed on test specimens taken from the coated components previously subjected to holiday detection (annex B), and in which an artificial defect of a defined size has been drilled. The test may be performed on the coated components without cutting test specimens.

#### E.2 Apparatus

##### E.2.1 Electrical source

The source for the voltage and the current shall consist of a stabilised DC, power unit <sup>1)</sup>. A cathodic polarisation potential of  $-1\,500$  mV to a saturated calomel reference electrode, (equivalent to  $U_H = -1\,260$  mV where  $U_H$  means the potential of the standard hydrogen electrode) shall be maintained.

- " $E$ " is the potential of the "working electrode" with regards to the "reference electrode".
- " $V$ " is the difference of potential between the "working electrode" and the "auxiliary electrode".

##### E.2.2 Electrolytic cell

For tests, typical test cell configuration are shown in Figure E.1 for large diameter components and in Figure E.2 for small diameter components.

The electrolytic cell shall comprise of:

- a) a rigid plastic tube of an internal diameter of minimum 50 mm. The height shall be such that the total volume of the electrolyte is equal or greater than 150 ml with a minimum height of the electrolyte of 70 mm;
- b) a rigid plastic cover in which holes shall be drilled to allow the passage of the electrodes and any other measuring instruments deemed necessary, and to allow the escape of hydrogen.

##### E.2.3 Electrodes

###### E.2.3.1 Reference electrode

The saturated calomel reference electrode or a suitable type of reference electrode to give an equivalent potential (see E.2.1) shall be placed in an electrode holder situated in a glass tube with a porous end plug. The end of this assembly shall be placed approximately 10 mm from the surface of the coating and approximately 20 mm from the coating defect.

The reference electrode used shall be suitable for the test temperature required.

---

<sup>1)</sup> The current source shall be capable of supplying 20 mA to each test area simultaneously.

### E.2.3.2 Auxiliary electrode

The auxiliary electrode shall consist of an inert material, e.g. platinum wire of 0,8 mm to 1,0 mm diameter. It shall be immersed in the electrolyte <sup>2)</sup>.

The ratio of the surface area of the anode and the cathode shall be greater than 1.

### E.2.3.3 Working electrode (cathode)

The working electrode is represented by the artificial defect which shall be 6 mm in diameter, with a maximum depth of 0,5 mm in the steel substrate (see E.3.5 and Figure E.3).

## E.2.4 Electrolyte

**E.2.4.1** The electrolyte shall consist of a solution of 3 % NaCl concentration in distilled or deionised water. The solution shall be made from annalar grade sodium chloride.

**E.2.4.2** The pH at  $(23 \pm 2)$  °C during the test shall be in the range of 6 to 9.

**E.2.4.3** The height of the electrolyte in the cell shall be  $(75 \pm 5)$  mm.

## E.2.5 Test temperature

For tests temperatures within the requirements of 7.10, the electrolyte shall not be cooled.

For test temperatures outside the requirements of 7.10, the test method shall be determined by agreement.

## E.2.6 Heating equipment

Suitable heating equipment shall be used to establish and to maintain the test temperature of the sample.

If not heated in an oven the temperature shall be checked on the artificial defect by an appropriate mean; e.g. a temperature sensor.

## E.3 Sampling

**E.3.1** The test specimen shall be cold cut from a coated component and shall have a minimum size of 80 mm x 80 mm, unless the test is performed on the body of the coated component.

**E.3.2** Tests samples shall not be taken from the weld area.

**E.3.3** For each sample the thickness of the area of the coating subject to the test, shall be measured and recorded.

**E.3.4** The integrity of the coating on all test samples shall be checked by holiday detection (see annex B).

**E.3.5** A 6 mm diameter flat bottom hole (see Figure E.3) shall be drilled through the coating in the centre of the test specimen using a self centring flat ended drill bit. The depth of the drilled hole in the steel substrate shall not exceed 0,5 mm. At the initiation of the test the total surface area subject to the test shall be free from residual coating.

**E.3.6** The test area shall be degreased using a suitable solvent and then rinsed with potable water and subsequently dried.

---

<sup>2)</sup> To approximately within 10 mm over the coating defect.

## E.4 Procedure

**E.4.1** The plastic tube forming the electrolytic cell shall be sealed using a suitable sealant, e.g. a chemically inert adhesive. The artificial defect shall be in the centre of the cell.

**E.4.2** The cell shall be filled with the NaCl electrolyte (see E.2.4.1.).

**E.4.3** A negative cathodic potential shall be applied between the reference and working electrodes (see Figure E.1 or E.2), with an accuracy of  $\pm 10$  mV. If a saturated calomel electrode is used the potential shall be  $-1\,500$  mV.

**E.4.4** The test shall be performed for the test period required (see 7.10). The level of the electrolyte shall be readjusted with distilled or deionised water, if necessary.

The following parameters shall be recorded:

- a) the current between the auxiliary electrode and the working electrode (cathode);
- b) the current density between the auxiliary and the working electrodes.

## E.5 Investigation procedure

**E.5.1** After the test the cell with the electrolyte shall be removed. The test specimen shall be rinsed with water and dried.

**E.5.2** After drying, the area of the coating subjected to the test shall be examined in accordance with the following method.

Inspect and assess each coating immediately after the test period. Detach the plastic tube from the test site. Using a lint-free paper towel, wipe along the surface of the coating and cathode area to remove moisture;

Make about 12 radial incisions using a sharp knife through the coating to the substrate extending outwards from the holiday for a distance of at least 40 mm. Make these incisions at an angle of approximately  $30^\circ$  from each other;

Insert the knife point into the centre portion of the holiday down to the metal substrate. Using a gentle levering action, peel away slowly a radial section of coating continuing until firm adhesion is encountered. As loss of adhesion is not always obvious, carefully examine the substrate for sign of residual coating which indicates that disbonding has not occurred.

Repeat with each radial segment.

## E.6 Results

Either report the extent of disbonding as average distance between the edge of holiday area and positions of firm adhesion; or if the coating is strongly adherent to the substrate, take the average distance at which the coating breaks as the extent of disbonding.

The result of the cathodic disbondment test is defined as the arithmetical mean value of the 12 single values.

The maximum single value of disbondment and the arithmetical mean value shall not exceed the values given in Table 4.

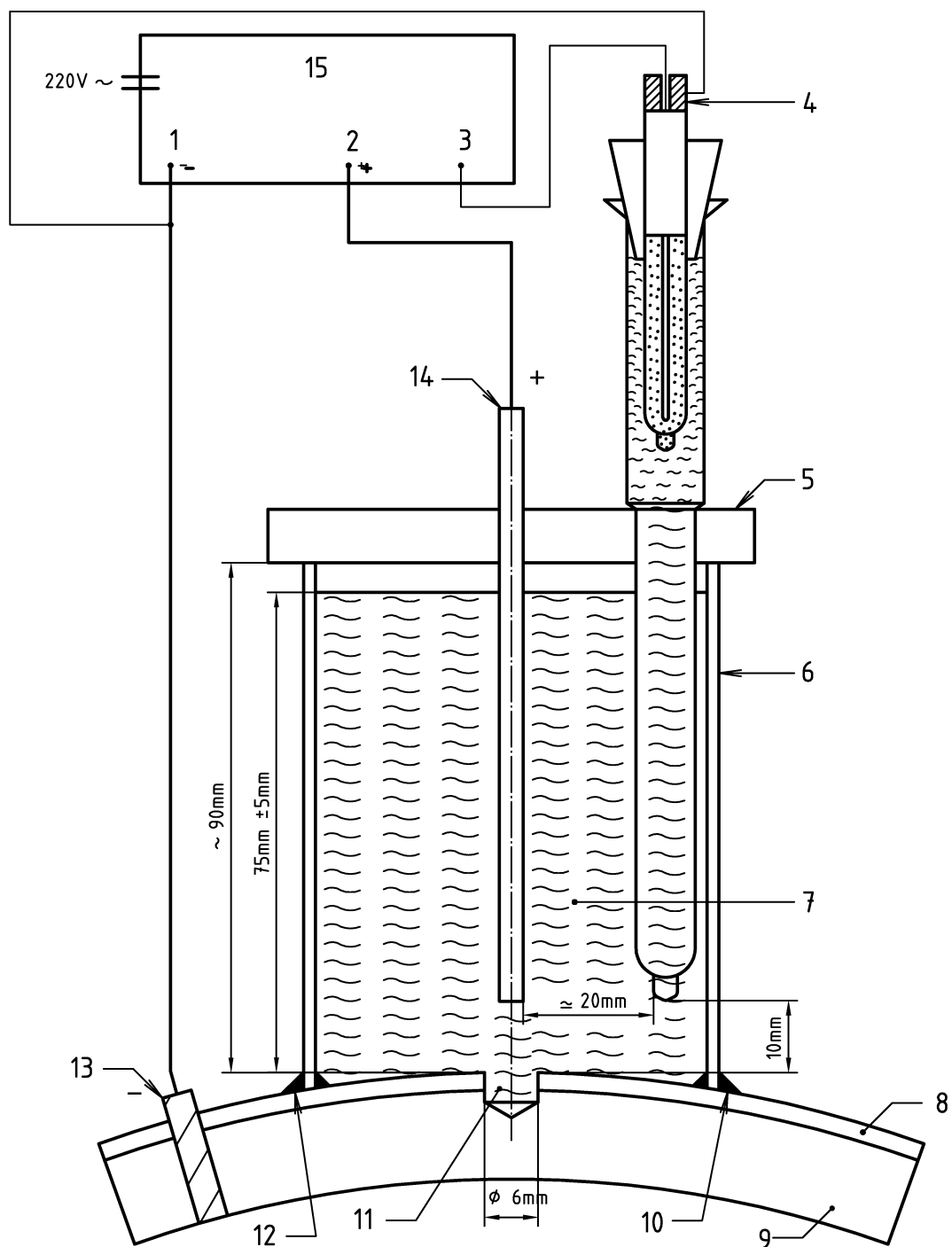

### Key

- |  |  |
|--|--|
| 1 Working electrode                                  | 8 Coating  |
| 2 Electrode (anode)                                  | 9 Steel test piece   |
| 3 Electrode (reference)                              | 10 Sealing material  |
| 4 Saturated calomel reference electrode              | 11 Artificial defect   |
| 5 Plastic cover                                      | 12 Sealing material  |
| 6 Plastic tube, minimum internal $\varnothing$ 50 mm | 13 Electrode (cathode)                                       |
| 7 Electrolyte $\geq$ 150 ml                          | 14 Platinum electrode $\varnothing$ 0,8 mm to 1,0 mm (anode) |
|  | 15 Potentiostat  |

Figure E.1 – Electrolytic cell

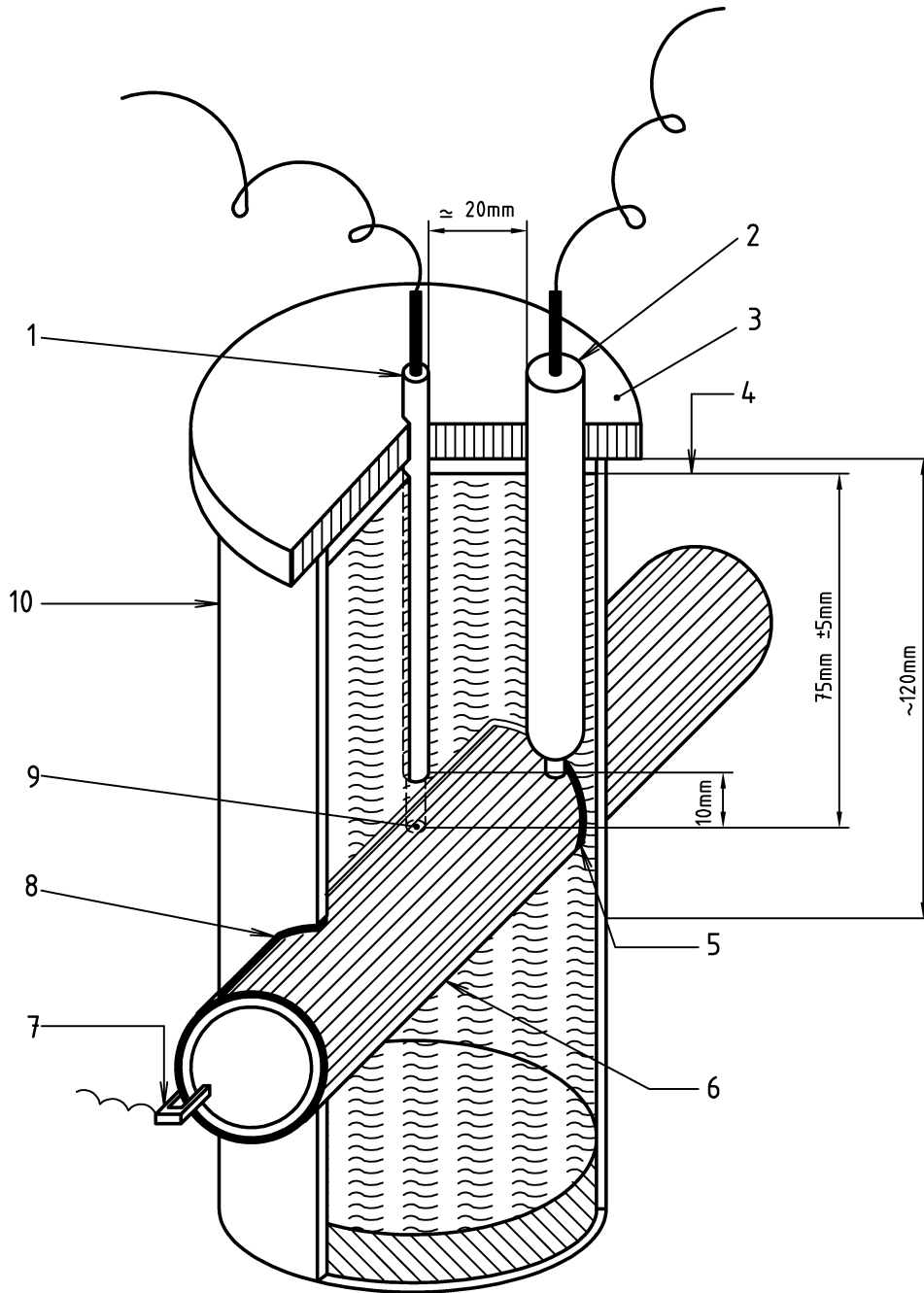

**Key**

- |   |   |
|---|---|
| 1 Platinum electrode $\varnothing$ 0,8 mm to 1,0 mm (anode) | 6 Coated tube   |
| 2 Saturated calomel reference electrode                     | 7 Working electrode (cathode)                         |
| 3 Plastic cover   | 8 Sealing material                                    |
| 4 Electrolyte level   | 9 Artificial defect $\varnothing$ 6 mm                |
| 5 Sealing material  | 10 Plastic tube, minimum internal $\varnothing$ 50 mm |

**Figure E.2 – Electrolytic cell for small diameter tube**

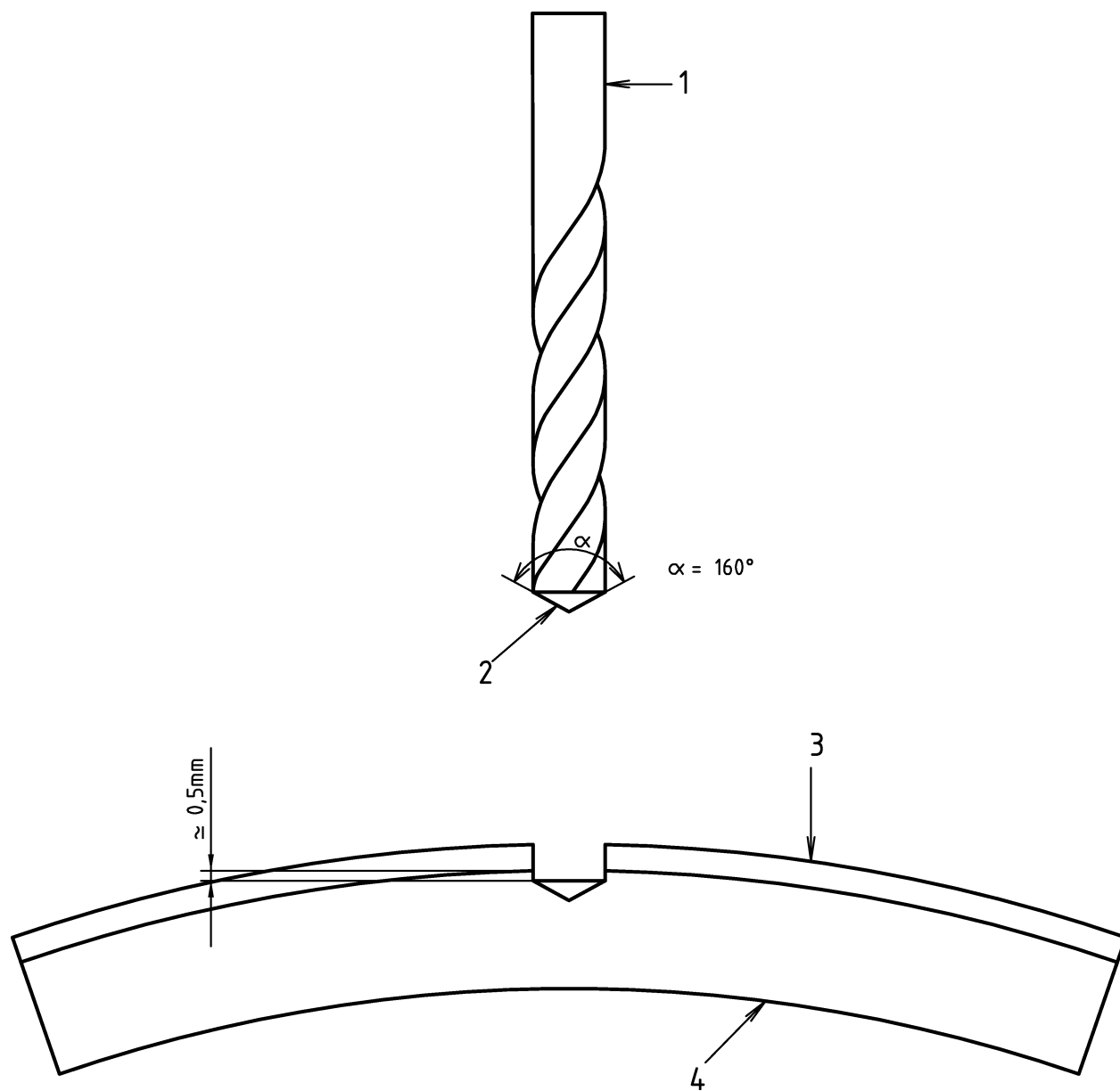

**Key**

- 1 Fluted and mill face mill  $\varnothing 6$  mm
- 2 Conic end
- 3 Coating
- 4 Steel

**Figure E.3 - Production of artificial defect**

## Annex F (normative)

### Specific electrical insulation resistance test

#### F.1 Test at ambient temperature ((23 ± 2) °C)

##### F.1.1 General

The test consists of measuring, at regular intervals, the specific electrical insulation resistance of the coating, on a piece of tube immersed continuously for a given time in a saline solution.

##### F.1.2 Apparatus

The apparatus shall consist of:

- a non metallic tank filled with demineralized water and sodium chloride to give a 0,1mol/l NaCl solution;
- a counter electrode e.g.a copper electrode;
- a direct current supply minimum voltage 50 V;
- a suitable ohmmeter or voltmeter and ammeter;
- suitable conductors for electrical connections;
- material for insulating the tank from the sample.

##### F.1.3 Procedure

The test shall be carried out at the temperature of (23 ± 2) °C.

A cylindrical section of tube, which has been cured, shall be used. A procedure in accordance with Figure F.1 or F.2 shall be carried out, in order to have an immersed test surface of at least 0,03 m<sup>2</sup>.

The immersed area (*S*) shall be assessed and recorded, in m<sup>2</sup>.

At regular intervals from the 3<sup>rd</sup> day of immersion and at least each week, the voltage *U* and the current *I* or the resistance *R* shall be measured. At the time of the measurement, using conductors, the positive pole of the current source or the ohmmeter shall be connected to the cylindrical section of the tube and the negative pole to the counter electrode, the minimum voltage of 50 V only being applied at the time of measurement.

The test shall be continued for 100 days.

##### F.1.4 Results

The insulation resistance *R<sub>s</sub>*, in Ohms.square metres, of the coating, measured at time *t*, shall be expressed as:

$$R_s = \frac{U S}{I}$$

where

$S$  is the immersed test surface, expressed in square metres (m<sup>2</sup>);

$U$  is the applied potential between the counter electrode and the steel tube, expressed in volts (V);

$I$  is the current passing between the counter electrode and the steel tube, expressed in amperes (A).

Between the 70<sup>th</sup> and 100<sup>th</sup> day, the linear regression line shall be calculated from the measured values. The slope  $\alpha$  of the line shall be determined and compared to the value at the start of the test;

where

$$\alpha = \frac{R_S(100 \text{ days})}{R_S(70 \text{ days})}$$

## F.2 Test at maximum service temperature

The test is performed as per F.1 with the following changes:

- test temperature : 40 °C, 60 °C or 80 °C ( $\pm 2$  °C) in accordance with the service temperature type of coating (see 1);
- test duration : 30 days;
- test procedure : the test medium is maintained at the maximum service temperature with a suitable method.

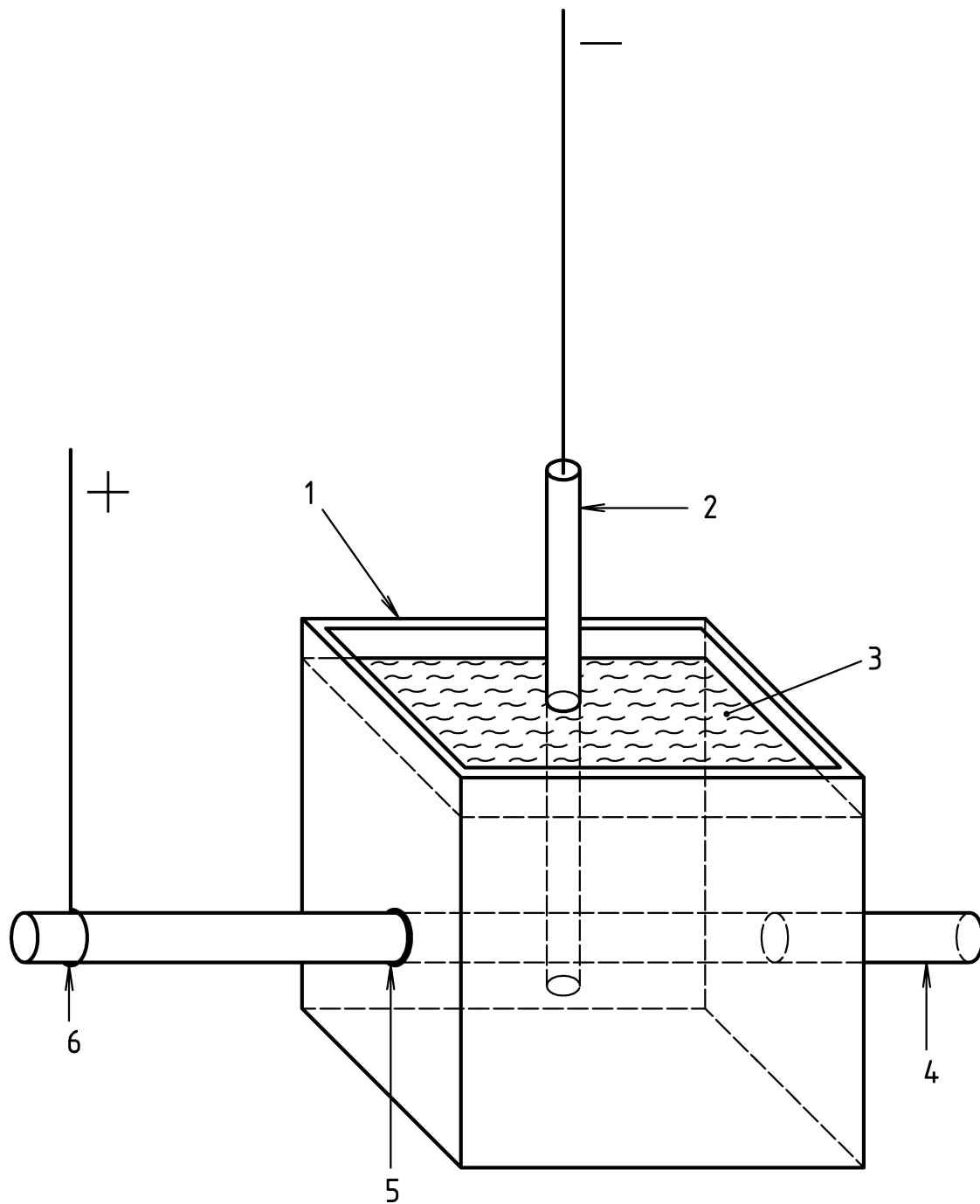

**Key**

- 1 Tank in insulating material
- 2 Copper electrode introduced only at the time measurement
- 3 NaCl solution
- 4 Tube with anti-corrosion coating
- 5 Sealing
- 6 Steel tube

**Figure F.1 - Testing provisions for small diameter tube**

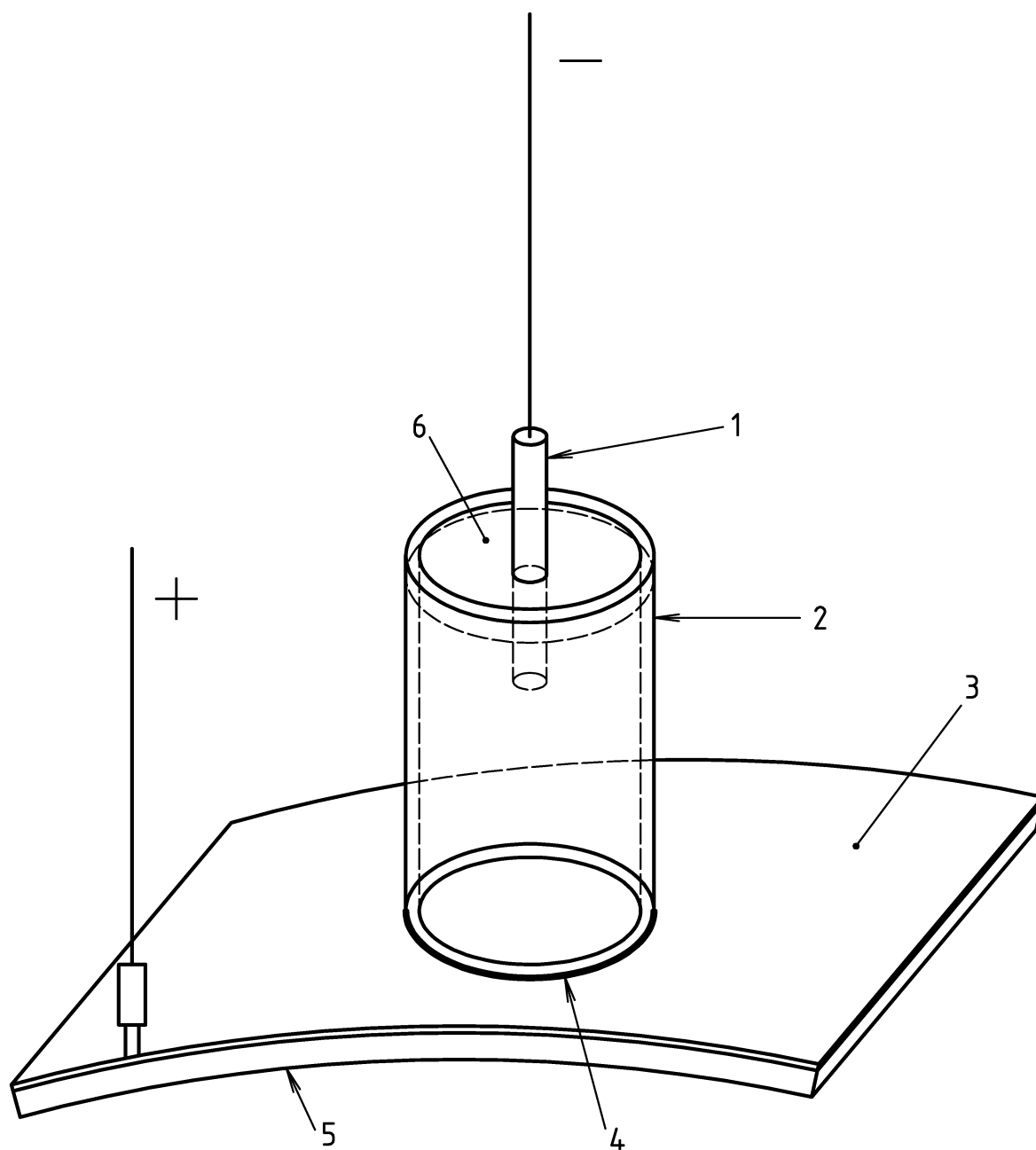
**Key**

- 1 Copper electrode introduced only at the time measurement
- 2 Tank in insulating material
- 3 Anti-corrosion coating
- 4 Sealing
- 5 Steel tube
- 6 NaCl solution

**Figure F.2 - Testing provisions for large diameter tube**

## Annex G (normative)

### Adhesion test after immersion in tap water

#### G.1 General

The test consists of determining the resistance to loss of adhesion of the coating by water absorption.

Specimens free from superficial moisture shall be holiday detected (annex B) before testing in order to ensure that there are no imperfections in the coating.

#### G.2 Apparatus

The apparatus shall consist of:

- a bath of tap water maintained at the maximum service temperature;
- an holiday detector (annex B);
- a piece of coated tube (test specimen);
- a pointed knife;
- an adhesive elastomer for repairing test areas.

#### G.3 Procedure

A specimen shall be cold cut from the tube chosen for test.

This specimen shall be holiday detected (annex B). For this test, the inside surface of the specimen shall be protected by a suitable coating.

An adhesion test in accordance with the requirements of annex D shall be undertaken; the test site shall be repaired. The specimen shall be suspended in the water bath so that it is submerged in the water.

After immersion for 100 hours the specimen shall be taken out of the bath and cooled to  $(23 \pm 2)$  °C. The adhesion test shall be carried out in accordance with the requirements of annex D.

#### G.4 Results

The appearance and continuity of the coating shall be inspected in accordance with 7.4 and the holiday detection shall be carried out in accordance with the method defined in annex B.

The adhesive loss in millimetres shall be tested in accordance with annex D.

## Annex H (normative)

### Indentation test

#### H.1 General

The test consists of measuring the indentation of a punch into the coating under fixed conditions of temperature and load.

#### H.2 Apparatus

The apparatus shall consist of:

- a chamber thermostatically controlled to  $\pm 2$  ° C;
- a penetrometer comprising:
  - a cylindrical punch of diameter 1,8 mm (cross-sectional area 2,5 mm<sup>2</sup>) on the top of which is mounted a weight. The assembly, punch plus weight, shall have produce a force of 25 N;
  - a dial gauge or any other measurement system accurate to  $10^{-2}$  mm.

#### H.3 Procedure

The test shall be performed three times on one coating sample.

The test piece, held within the penetrometer assembly, shall be placed in the thermostatically controlled chamber and set to the test temperature. The test piece shall be allowed to stand for 1 h. The reading on the dial gauge shall be recorded.

The shock resistant punch with the mass giving 2,5 kg in total shall be loaded to the apparatus. The test shall be allowed to stand for 24 h. The reading of the dial gauge shall be recorded.

NOTE When sampling of the test piece is unpractical (e.g. in the case of large diameter components), the test can be carried out on panels.

#### H.4 Results

The indentation shall be the difference between the dial gauge reading before and after the 24 hours test duration. The arithmetic mean of the three indentation measurements shall be calculated.

## Annex J (normative)

### Thermal ageing

#### J.1 General

The test consists of assessing the comparative resistance to accelerated ageing by measuring the loss of adhesion after exposure to dry heat from a thermostatically controlled oven.

#### J.2 Apparatus

The apparatus shall consist of a thermostatically controlled oven with pulsed air which can maintain a test temperature with an accuracy of  $\pm 2$  °C.

#### J.3 Sampling

**J.3.1** The test specimens shall be cold cut from a coated component, unless the test is performed on panels.

**J.3.2** Tests samples shall not be taken from the weld area.

**J.3.3** For each sample the thickness of the area of the coating subject to the test, shall be measured and recorded.

**J.3.4** The integrity of the coating on all test samples shall be checked by holiday detection (see annex B).

#### J.4 Procedure

Samples shall be conditioned in the oven at 60 °C, 80 °C or 100 °C ( $\pm 2$  °C) in accordance with the service temperature and type of the coating (see 7.14).

After 100 days, two samples at a time are withdrawn from the oven and after cooling at room temperature, checked by pull-off in accordance with EN 24624 (cutting around dolly). Surface defects shall be detected in accordance with annex B, and any visible changes in the coating shall be recorded.

#### J.5 Results

The appearance and continuity of the coating shall be inspected in accordance with 7.4 and the holiday detection shall be carried out in accordance with the method defined in annex B.



## Annex K (normative)

### Types of inspection documents

Standard designation	Document	Type of control	Contents of document	Delivery conditions	Document validated by
2.1	Certificate of compliance with the order	Non-specific	Without mention of test results	In accordance with the requirements of the order, and if required, also in accordance with official regulations and the corresponding technical rules	The manufacturer
2.2	Test report		With mention of test results carried out on the basis of non specific inspection and testing		
2.3	Specific test report	Specific	With mention of test results carried out on the basis of specific inspection and testing	In accordance with official regulations and the corresponding technical rules	The inspector designated in the official regulations
3.1.A	Inspection certificate 3.1.A				
3.1.B	Inspection certificate 3.1.B			In accordance with the specification of the order, and if required, also in accordance with official regulations and the corresponding technical rules	The manufacturer's authorized representative independent of the manufacturing department
3.1.C	Inspection certificate 3.1.C			In accordance with the specifications of the order	The Purchaser's authorized representative
3.2	Inspection certificate 3.2				The manufacturer's authorized representative independent of the manufacturing department and the Purchaser's authorized representative

## Annex L (informative)

### A-Deviation

A-deviation: National deviation due to regulations, the alteration of which is for the time being outside the competence of the CEN/CENELEC member.

This European Standard does not fall under any Directive of the EC.

In the relevant CEN/CENELEC countries, these A-deviations are valid instead of the provisions of this European Standard until they have been removed.

#### Netherlands

Reference to legal requirements in the Netherlands (concerning underground liquid storage in tanks)

- Royal Decree nr. 46 (1993): Besluit van 15 januari 1983, houdende regels met betrekking tot het opslaan van vloeistoffen in ondergrondse tanks (Besluit opslaan in ondergrondse tanks)
- Commissie Preventie van Rampen door Gevaarlijke Stoffen CPR 9-1 "Ondergrondse opslag in stalen tanks en afleverinstallaties voor motorbrandstof. Opslag in grondwaterbeschermings-gebieden".
- NEN 6905 d.d. april 1983 "Uitwendige epoxy bekledingen van ondergronds te leggen stalen buizen en hulpstukken".

For tubes and fittings connected to tanks the following deviations apply:

- 5.3:
  - Safety Hazard symbols shall be included on the packaging of each container and Safety Data Sheets shall be provided by the manufacturer.
- 7.3 and annex H:
  - The hardness shall be measured by the Buchholz indentation test in accordance with ISO 2815 (instead of the Shore D test in accordance with EN ISO 868). Subsequently, the coating shall be subject to exposure to methylisobutylketone for a period of one hour and the hardness measured again. A maximum decrease of 20% from the initial value is allowed.
- 7.6 and annex B:
  - The holiday detection shall be carried out using a voltage of 6 V per  $\mu\text{m}$ .
- 7.10 and annex E:
  - The cathodic disbonding test shall be carried out in accordance with ASTM G8 for a period of 90 days at  $(23 \pm 2) ^\circ\text{C}$  whereby the maximum radius of disbondment shall not exceed 6 mm.

## Bibliography

ISO 4287-1, *Surface roughness - Terminology - Part 1: Surface and its parameters.*

---

---

## BSI — British Standards Institution

BSI is the independent national body responsible for preparing British Standards. It presents the UK view on standards in Europe and at the international level. It is incorporated by Royal Charter.

### Revisions

British Standards are updated by amendment or revision. Users of British Standards should make sure that they possess the latest amendments or editions.

It is the constant aim of BSI to improve the quality of our products and services. We would be grateful if anyone finding an inaccuracy or ambiguity while using this British Standard would inform the Secretary of the technical committee responsible, the identity of which can be found on the inside front cover. Tel: +44 (0)20 8996 9000. Fax: +44 (0)20 8996 7400.

BSI offers members an individual updating service called PLUS which ensures that subscribers automatically receive the latest editions of standards.

### Buying standards

Orders for all BSI, international and foreign standards publications should be addressed to Customer Services. Tel: +44 (0)20 8996 9001. Fax: +44 (0)20 8996 7001. Email: [orders@bsi-global.com](mailto:orders@bsi-global.com). Standards are also available from the BSI website at <http://www.bsi-global.com>.

In response to orders for international standards, it is BSI policy to supply the BSI implementation of those that have been published as British Standards, unless otherwise requested.

### Information on standards

BSI provides a wide range of information on national, European and international standards through its Library and its Technical Help to Exporters Service. Various BSI electronic information services are also available which give details on all its products and services. Contact the Information Centre. Tel: +44 (0)20 8996 7111. Fax: +44 (0)20 8996 7048. Email: [info@bsi-global.com](mailto:info@bsi-global.com).

Subscribing members of BSI are kept up to date with standards developments and receive substantial discounts on the purchase price of standards. For details of these and other benefits contact Membership Administration. Tel: +44 (0)20 8996 7002. Fax: +44 (0)20 8996 7001. Email: [membership@bsi-global.com](mailto:membership@bsi-global.com).

Information regarding online access to British Standards via British Standards Online can be found at <http://www.bsi-global.com/bsonline>.

Further information about BSI is available on the BSI website at <http://www.bsi-global.com>.

### Copyright

Copyright subsists in all BSI publications. BSI also holds the copyright, in the UK, of the publications of the international standardization bodies. Except as permitted under the Copyright, Designs and Patents Act 1988 no extract may be reproduced, stored in a retrieval system or transmitted in any form or by any means – electronic, photocopying, recording or otherwise – without prior written permission from BSI.

This does not preclude the free use, in the course of implementing the standard, of necessary details such as symbols, and size, type or grade designations. If these details are to be used for any other purpose than implementation then the prior written permission of BSI must be obtained.

Details and advice can be obtained from the Copyright & Licensing Manager. Tel: +44 (0)20 8996 7070. Fax: +44 (0)20 8996 7553. Email: [copyright@bsi-global.com](mailto:copyright@bsi-global.com).